



Cell Illustrator™: Reference Manual

**© 2002-2010 Human Genome Center, Institute of Medical Science,
The University of Tokyo**

All rights reserved.

TABLE OF CONTENTS:

CELL ILLUSTRATOR™: REFERENCE MANUAL	1
1 INTRODUCTION.....	7
2 CI ONLINE	8
3 BIOPATHWAY AND GENE NET MODEL	9
3.1 Differences between Gene Net and Biopathway Model	9
3.2 Documentation.....	10
4 MAIN WINDOW.....	11
5 MENU BAR.....	12
5.1 File New.....	12
5.2 File Open.....	12
5.3 File Open Recent Files.....	14
5.4 File Close File.....	14
5.5 File Close All Files	14
5.6 File Save.....	15
5.7 File Save As.....	15
5.8 File Insert.....	15
5.9 File Export	16
5.10 File Export All.....	18
5.11 File Export to Cytoscape.....	18
5.12 File Look & Feel	19
5.13 File Print Visible Area	19
5.14 File Print.....	19
5.15 File Exit	19
5.16 Edit Undo.....	20
5.17 Edit Redo.....	20
5.18 Edit Cut	20
5.19 Edit Copy	21
5.20 Edit Paste	21
5.21 Edit Paste View Style	21
5.22 Edit Delete.....	22
5.23 Edit Duplicate.....	22
5.24 Edit Extract.....	22
5.25 Edit Find.....	22
5.26 Edit Select All.....	23
5.27 Edit Select None.....	23
5.28 Edit Select Inverse	23
5.29 Edit Align To Grid	23
5.30 Edit Align To.....	24

5.31	Edit Move To.....	24
5.32	Edit Insert Entity	25
5.33	Edit Insert Process.....	25
5.34	Edit Insert Image	25
5.35	Edit Insert Text	26
5.36	Edit Insert Frame.....	26
5.37	Element Show All	26
5.38	Element Hide	26
5.39	Element Element Type	27
5.40	Element Connector Type	27
5.41	Element Reverse Direction.....	27
5.42	Element Arrange	28
5.43	Element Group	28
5.44	Element Ungroup	29
5.45	Element Size.....	29
5.46	Element Fill Color.....	29
5.47	Element Line Color	29
5.48	Element Line Style	29
5.49	Element Stroke	30
5.50	Element Remove All Anchors	30
5.51	Element Set Image	30
5.52	Element Set Image Type	31
5.53	Element Edit Image	31
5.54	Element Resize Image	31
5.55	Element Edit Chemical Structure.....	32
5.56	Element References	32
5.57	Element URL Templates.....	33
5.58	Element Label.....	33
5.59	Element Show Name.....	33
5.60	Element Show Variable.....	34
5.61	Element Show Value	34
5.62	Element Show Firing Style	34
5.63	Element Log.....	35
5.64	Element Create Chart.....	35
5.65	Element Update Location	35
5.66	Simulation Play.....	35
5.67	Simulation Step Play	36
5.68	Simulation Pause	36
5.69	Simulation Stop And Initialize.....	37
5.70	Simulation Fast Play	37
5.71	Simulation Max Speed Play	37

5.72	Simulation Run Reference Simulation.....	38
5.73	Simulation Run Parameterized Simulation	38
5.74	View Mode.....	39
5.75	View Zoom In.....	39
5.76	View Zoom Out.....	39
5.77	View Actual Size.....	40
5.78	View Fit In Canvas	40
5.79	View Duplicate Canvas	40
5.80	View Delete Canvas	41
5.81	View Show All Charts	41
5.82	View Hide All Charts.....	41
5.83	View Show Grid.....	41
5.84	View Antialiasing	42
5.85	View Grid Size	42
5.86	View Background Color.....	42
5.87	Analyze Extract Subnet.....	42
5.88	Analyze Select Downstream	43
5.89	Analyze Select Upstream	43
5.90	Analyze Select Both	43
5.91	Analyze Keyword Search.....	43
5.92	Analyze Path Search.....	44
5.93	Analyze Entity List Search.....	44
5.94	Analyze Compare.....	44
5.95	Analyze Gene Mining	45
5.96	Analyze Generate Gene References.....	45
5.97	Analyze Download Gene Mining Database	45
5.98	Select Upstream.....	46
5.99	Select Downstream.....	46
5.100	Select Up- and Downstream	46
5.101	Select Inverse	47
5.102	Select All.....	47
5.103	Select None.....	47
5.104	Window Tile Horizontal	48
5.105	Window Tile Vertical	48
5.106	Window Maximize Canvas	48
5.107	Window Open Perspective	48
5.108	Window Reset Perspective.....	49
5.109	Window Show Frame	49
5.110	Window Hide All Frames.....	49
5.111	Window Restore All Frames.....	50
5.112	Window Preferences	50

5.113	Help Cell Illustrator Help	50
5.114	Help User Guide.....	50
5.115	Help Cell Illustrator Online.....	51
5.116	Help CSML Online	51
5.117	Help Cell Illustrator User Forum	51
5.118	Help About Cell Illustrator	51
6	TOOLBARS	52
6.1	Library Toolbar.....	52
6.2	Draw Toolbar.....	52
6.3	File Toolbar	54
6.4	Edit Toolbar	54
6.5	Simulation Toolbar	55
6.6	Dialog Toolbar.....	55
7	DRAWING CANVAS	57
7.1	Multiple Views	57
7.2	Canvas Popup Menus	57
8	FRAMES.....	60
8.1	Element Lists.....	60
8.2	Element Settings	64
8.3	Navigator	74
8.4	Simulation Settings	75
8.5	Chart Settings	77
8.6	Simulation History	79
8.7	Biological Elements.....	80
8.8	Graph Layout	82
8.9	Gene Mining.....	83
8.10	External References	86
8.11	Comments	86
8.12	Project Manager	87
8.13	CSMLDB Search	90
8.14	Parts Library.....	96
8.15	BioPACS Library.....	97
8.16	View Settings	98
8.17	Biological Properties	100
8.18	Simulation Errors.....	101
8.19	Path Search Results	102
8.20	Expression Plot.....	102
9	DIALOG BOXES	104
9.1	CI Online Login Dialog	104
9.2	Preferences.....	105

9.3	Compare	105
9.4	Manage User Databases	107
9.5	Chart Window	110
9.6	Keyword Search	112
9.7	Path Search.....	113
9.8	Entity List Search	115
9.9	Reference Simulation	117
9.10	SECG Passing Parameters	118
9.11	Parameterized Simulation Results	118
9.12	About Cell Illustrator.....	119
10	OTHER.....	120
10.1	CSO Class Tree	120
10.2	Script Editor.....	120
10.3	Kinetic Styles Editor	128
10.4	SECG	131

1 Introduction

Cell Illustrator™ (CI) is a software tool that enables biologists to model, elucidate and simulate complex biological processes and systems. It allows researchers to model metabolic pathways, signal transduction cascades, gene regulatory pathways as well as dynamic interactions of various biological entities such as genomic DNA, mRNA and proteins. Cell Illustrator models are used to visualize biopathways, interpret experimental data and test hypotheses. In addition, it provides researchers with model diagrams of publication quality and simulation result charts.

Using a graphical user interface environment, researchers can create and simulate their own molecular pathway models. Some of the key features of Cell Illustrator are: (a) Pathway construction and visualization—construct models graphically by drag and drop Entities that represent bio-components in the biological pathways; (b) Pathway simulation—specify mathematical formulas for biochemical reactions in the pathway for simulation; The simulation can be run inside the workspace window in an interactive mode, or it can be sent to a remote server (Cell Illustrator Server) (c) Gene relationship net visualization and analysis (d) Model import - previously created models or sub-models can be imported from SBML, CellML files or from public or proprietary libraries and databases like Transpath or KEGG.

The documentation for the Cell Illustrator software includes the manuals listed below:

Cell Illustrator User Guide: Introduction to Cell Illustrator system

Cell Illustrator Reference Manual: Detailed description of Cell Illustrator functions

This manual is a reference for the functional features of Cell Illustrator Online version 5.0 (CIO5.0). It can be used to answer questions about specific system commands. For installation instructions and an introduction to modeling biological pathways with Cell Illustrator, please refer to the User Guide.

2 CI Online

Until version 3.0 Cell Illustrator was offered as desktop application. Since version 4.0 Cell Illustrator is available as Java Web Start application – *CI Online*. CI Online can be run directly from the website, without the need to install software on local computer.

CI Online is a client-server solution that enables the user to create, manipulate and simulate bio-pathway models locally within CI workspace and to store and organize them on the remote CI Online Server. Additionally CI Online gives the user convenient access to libraries and databases of bio-pathway models.

In CI Online, Cell Illustrator is the front-end, where the user prepares a pathway and simulates it. The Cell Illustrator client communicates with the CI Online Server over the internet (HTTP or HTTPS protocol). The CI Online Server is a place where the user logs-in to store and manage his pathways and to share them with other users.

3 Biopathway and Gene Net Model

Since the version 3.0, Cell Illustrator enables the users to view and analyze models of two types:

- (i) Biopathway
- (ii) Gene Relationship Net

Biopathway models represent complex biological processes and systems using Petri Net models for the simulation of time dependent processes.

A typical *Gene Net* cannot be simulated. Originally a gene net does not contain any data useful for the Petri Net based simulation. However such a net can be used as the starting point for creating a simulatable biopathway model.

3.1 Differences between Gene Net and Biopathway Model

The differences between *Biopathway* and the *Gene Net* model are listed in the table below.

	Biopathway Model	Gene Net Model
Model	<p>Includes 3 base elements: entity, process and connector.</p> <p>Models are created by the user within CI workspace.</p> <p>Biopathway models are smaller but more precisely defined than the Gene Net models.</p> <p>Biopathway models include quantitative simulation properties for studying the kinetics of biological processes.</p>	<p>Includes 2 basic elements: entity and edge (fact edge)</p> <p>Gene networks are automatically generated by special external software.</p> <p>Originally gene networks are large models without precise simulation data.</p>
Visualization	<p>More advanced graphics: images for each graph elements, polygon and curved edges for connectors, visualization and animation of simulation</p>	<p>Simple graphics: default view styles for each gene and edge.</p> <p>Visualization is faster but includes less details. Thus it is more suitable for large</p>

	<p>progress, etc.</p> <p>Visualization is slower but allows for displaying more details.</p>	networks.
Editing	Many commands enable building biopathway models from the scratch and defining the simulation properties (e.g. kinetic styles)	Extraction and Merging of subnetworks. Other edit commands are used in seldom cases.
Simulation	Simulation using Petri Net algorithm.	no Simulation capabilities
Analysis	Analysis of simulation results: charts	Analysis of gene networks: Gene Mining, Pathway and Keyword Search, tools for extraction of subnets

3.2 Documentation

Please refer to the **CI User Guide** to get more information how to create and simulate biopathway models, or to **CI Gene Net User Guide** to learn more about the gene net visualization and exploration capabilities.

4 Main Window

The Workspace is the main window of Cell Illustrator. The **Menu Bar** located at the top provides a set of commands for building and manipulating a model. Frequently used commands can be also executed by pushing a button on one of the **Toolbars** on the sides of Workspace. Menu items and toolbar buttons corresponding to operations that cannot be performed at the moment are disabled (grayed out).

In the Workspace, multiple model files can be opened simultaneously for viewing and editing. A model file is displayed in a one or more **Drawing Canvas**. The canvas window is the main view of the model and allows the model to be edited and a simulation run to be watched. You can open several canvas windows to view different parts of the model.

In Cell Illustrator, the user can open several **Frames**. The contents of these frames reflect:

- user preferences (applicable to all models),
- properties of the model in the active canvas window, or
- properties of a selected elements in the active canvas window.

Beside the property frames, Cell Illustrators offers frames that support building of pathways. These frames give the user the access to many predefined elements or pathway fragments and the ability to insert these fragments to the active canvas.

5 Menu Bar

5.1 File | New

Description:

- Creates a new, empty model with one view.
- The model name is “New Model *number*”, where the number is the number of currently opened models + 1
- CTRL+N is the keystroke shortcut for this command.

Constraints:

- None

5.2 File | Open

Description:

- Opens a model from a file and displays it in the workspace. Cell Illustrator loads data from the native CSML format as well as from other formats.
- The format of the file can be selected in the *File Type* combo box.
- CI tries to recognize the format of the selected file by analyzing its contents. If the “recognized” format is different than the format selected in *File Type*, the warning will be displayed prompting the user: *Do you want to open the file with a different file filter?*
- CTRL+O is the keystroke shortcut for this command.
- It is not possible to open the same file twice. If the user attempts to open a file that is already opened, then the canvas window of that file is activated and displayed in the foreground.

CSML Files – the CI “native” File Format

- The native CI file format is the XML format called CSML – Cell System Markup Language - www.csml.org
- The CSML files can be written in various versions: CSML 3.0, which normally should have .csml extension or the older CSML 1.9 files which normally have the .gon extension. This command opens all versions of CSML files.
- Models created and simulated in CI 4.0 included Pnuts scripts only. Simulation of these models in CI 5.0 might cause script execution errors, since Pnuts is NOT the default scripting language of CI 5.0. In order to simulate such models in CI 5.0, it is recommended to check the *Default Script Language* in *Simulation Settings* frame of the model and set its value to *Pnuts*.
- Since a CI Log (.cil extension) stores the model in the same format as in the original project file, you can open a log file with Cell Illustrator as well and edit the model. However, saving the edited model into the original log file will erase the time series and any other simulation history information. Therefore, you should use the Save As command of Cell Illustrator if you would like to recover the model from a log file for further editing.

Other File Formats

- File | Open command also opens models from other, non-CSML formats, such as: SBML, CellML, BioPAX, CSO, CSV.
- After importing a non-CSML file, it is recommended to save it to a CSML file using the File | Save as command.

CSV – Edge Files

- Imports gene networks from a normal text file with tab or comma separated values. The tab separated value files should have the extension *.tsv or *.txt, while comma separated values *.csv
- The text file should contain the connection table – a list of edges.
- Each row in this text file represents an edge. The edge is described by several tab (or comma) separated values as follows:

<parent > <child> <property1> <property2> etc..

- The first two columns must define *name* of the *Parent* and *Child* entity of each edge. The next columns might defined the properties of the edge.
- The text file might include a header row with the description of defined columns. The first and second row must be named *Parent* and *Child*, the next property names can be defined by the user.
- If the file does not include column headers, then the columns will be recognized as follows:

<parent> <child> <edgeScore> <relationType> <bspline>

BioPAX/CSO

- Imports/converts a pathway model from a CSO/BioPAX file to a CI model and opens it in a new canvas.
- The imported Biological Pathway Exchange (BioPAX) models should conform to the specification of BioPAX level 2 at www.biopax.org
- The imported Cell System Ontology (CSO) models should conform to the specification of CSO at www.csml.org. CSO supports most of CSML features and allows for more flexible and extensible handling of biological data using Semantic Web OWL and RDF languages.
- The imported BioPAX/CSO files can be saved to a CSML file using the **File | Save As** command or exported to CSO using the **CSO Model**.

SBML/CellML

- SBML/CellML models differ from the CI ones. E.g. SBML uses differential equations for representing relationships between entities, while CI use the Petri Net model. Therefore the conversion process has the following limitations:
 - o Not all SBML models can be imported to CI
 - o the simulation results might differ, for a SBML model imported to CI.
- It is recommended to run a simulation after a successful model import to verify whether the results of the converted model are identical to the

simulation results of the original SBML model. Before running the simulation, the user should check and set the proper *Simulation Time* and *Sampling Interval* in the **Simulation Settings** frame.

Constraints:

- None

5.3 File | Open Recent Files

Description:

- Displays a list of recently opened files. Click on an item in the list to open the corresponding file.
- Up to 14 recently opened files are in the list.
- The list does not contain duplicates.
- It is not possible to open the same file twice. If the user attempts to open a file that is already opened, then the canvas window of that file is activated and displayed in the foreground.

Constraints:

- You can not execute this command if a simulation is running.

5.4 File | Close File

Description:

- Closes the active model file without exiting the program.
- If a file has been modified, you are prompted to save the changes before closing the file.
- CTRL+W is the keystroke shortcut for this command.

Constraints:

- At least one canvas window must be opened in the workspace.

5.5 File | Close All Files

Description:

- Closes all model files without exiting the program.
- If a file has been modified, you are prompted to save the changes before closing the file.
- You are always prompted for a file name if you want to close a canvas created with the File | New command.

- CTRL+Shift+W is the keystroke shortcut for this command.

Constraints:

- At least one canvas window must be opened in the workspace.

5.6 File | Save

Description:

- Saves the active canvas in a file under the current filename.
- The model is saved in the CSML 3.0 file
- The saved file can be opened in CI workspace again using the File | Open command.

Constraints:

- At least one canvas window must be opened in the workspace.

5.7 File | Save As

Description:

- Saves the active file under a new filename selected by the user.

Constraints:

- At least one canvas window must be opened in the workspace.

5.8 File | Insert

- Model
- As Group
- As Object

Description:

- Inserts the elements from a Cell Illustrator model file into the active canvas.
- *Insert Model* inserts the elements of the external file as they are.
- *Insert Group* inserts the contents of the external file as one group.
- *Insert Object* inserts the contents of the external file as one hierarchical object.
- All inserted elements are in the selected state after the operation completes.
- All previously selected elements become deselected.
- The inserted item (a model, a group or an object) is placed in the center of the visible area of the canvas.

- For multiple views of one model, the inserted elements are visible in the active view only. In all other views, they are invisible. To make it visible, select the elements in *Element List* frame and check the *Visible* checkbox.

Constraints:

- At least one canvas window must be opened in the workspace.

5.9 File | Export

5.9.1 Simulation Source Code

- Java
- C
- C++
- Fortran
- Perl
- Python

Description:

- For the model in the active canvas, generates and exports the source code in the selected language
- The source code can be afterwards compiled and executed, resulting in a program which performs simulation of the model
- Compilation of java program requires a few additionally library classes which are located in the directory org, package org.csml.hfpne.engine. This library classes also provide a way of executing compiled engine, by starting the java program from EngineRunner class
- For all other languages except java, additional files are needed. These files will be saved in the directory where the main engine file exists (if they aren't there yet)

Constraints:

- At least one canvas is opened in the workspace

5.9.2 Image

Description:

- Exports active canvas to JPEG or PNG file
- File name and location is selected by user in dialog window

5.9.3 CSO Model

Description:

- Exports a pathway model from the active canvas to a Cell System Ontology (CSO) file.
- The exported CSO models conform to the specification of CSO at www.csml.org
- After exporting the CSO file, it can be imported to the CI workspace using the **File | Insert** command
- CSO supports most of CSML features and allows for more flexible and extensible handling of biological data using Semantic Web OWL and RDF languages.

Constraints:

- None.

5.9.4 SVG

Description:

- The command exports the active canvas to the Scalable Vector Graphics (SVG) file.

Constraints:

- At least one canvas window must be opened in the workspace.

5.9.5 HTML Report

Description:

- Exports the model in the active canvas to a file in HTML format.

Constraints:

- At least one canvas window must be opened in the workspace.

5.9.6 Simulation Log

Description:

- Exports the model in the active canvas and a CSV file with log data to a Cell Illustrator log file (CIL).
- CIL files are CSML (XML) files that consist of two sections: the main model and the simulation log. CIL files can be opened in CI Player and the logged simulation run can be viewed and replayed in an interactive way.
- Similar operation can be done in the **Simulation History** frame

Constraints:

- At least one canvas window must be opened in the workspace.

5.10 File | Export All

5.10.1 PNG

Description:

- Exports all views from current model or all models to a series of PNG image file
- The user chooses the destination folder in dialog window. If the selected folder exists a warning is displayed that files in this folder can be overwritten.
- Additionally the user may choose what should be exported, selecting one of the two options *Export all views of active model* (default value), or *Export all views of all opened models*

5.10.2 JPEG

Description:

- Exports all views from current model or all models to a series JPEG image file,
- The user can choose destination folder in dialog window. If the selected folder exists a warning is displayed that files in this folder can be overwritten.
- Additionally the user may choose what should be exported, selecting one of the two options *Export all views of active model* (default value), or *Export all views of all opened models*

5.11 File | Export to Cytoscape

Description:

- Opens the model from the active canvas in the external Cytoscape application.

Constraints:

- At least one canvas window must be opened in the workspace.

5.12 File | Look & Feel

- Metal
- CDE/Motif
- Windows
- Windows Classic

Description:

- With these commands, you can set the look and feel of Cell Illustrator to a GUI selected style.
- The selected GUI style is preserved upon restart of the program

5.13 File | Print Visible Area

Description:

- Prints the area that is visible in the canvas window
- With this command, you can print a part of the active canvas. To do this, first scroll and zoom the view in the active canvas and then choose this command.
- The command opens the **File | Print** dialog where you can select printer and specify page setup and appearance.

Constraints:

- At least one canvas window must be opened in the workspace.

5.14 File | Print

Description:

- With this command, you can print the whole graph in the active canvas.
- The command opens the **File | Print** dialog where you can select printer and specify page setup and appearance.

Constraints:

- At least one canvas window must be opened in the workspace.

5.15 File | Exit

Description:

- Exits the application.

- If any of the opened files has been modified after the last save operation, you will be prompted to save the changes before closing the file.

5.16 Edit | Undo

Description:

- Reverses the most recent edit action for the active model. If this model is displayed in multiple views, the active view will be changed to that view which has been edited.
- Execute this command several times to undo results of subsequent edit commands.
- CTRL+Z is the keystroke shortcut for this command.

Constraints:

- There is an action to undo.

5.17 Edit | Redo

Description:

- Reverses the action of the last Undo command for the active model. If this model is displayed in multiple views, the active view will be changed to that view which has been edited.
- Effects of subsequent Undo commands are reversed by executing the corresponding sequence of Redo commands
- Shift+CTRL+Z is the keystroke shortcut for this command.

Constraints:

- There is an action to redo.

5.18 Edit | Cut

Description:

- Removes the selection from the active canvas and places it in the clipboard.
- CTRL+X is the keystroke shortcut for this command.

Constraints:

- At least one element must be selected in the active canvas.

5.19 Edit | Copy

Description:

- Copies the selected elements into the system clipboard
- CTRL+C is the keystroke shortcut for this command.

Constraints:

- At least one element must be selected in the active canvas.

5.20 Edit | Paste

Description:

- Inserts the contents of the clipboard into the active canvas
- CTRL+V is the keystroke shortcut for this command.
- For multiple views of one model, the inserted elements are visible in the active view only. In all other views, they are invisible. To make it visible, select the elements in *Element List* frame and check the *Visible* checkbox.

Constraints:

- At least one canvas window must be opened in the workspace.
- The clipboard must contain elements copied with the Copy or Cut operation.

5.21 Edit | Paste View Style

Description:

- Copies the view style of the graph element (vertex or edge) from the clipboard to the elements selected in the active graph
- Before executing this command copy exactly one element with the desired view style to the clipboard using **Edit | Copy**
- After executing this command, the *Paste View Style* dialog box is displayed. In this dialog you may select the list of properties (such as size, line color, stroke, shape, image, font, etc.) to be copied from the clipboard element to the selected canvas elements.

Constraints:

- At least one canvas window must be opened in the workspace.
- The clipboard must contain exactly one vertex or edge copied with the Copy or Cut operation.

5.22 Edit | Delete

Description:

- Deletes the selected elements from the canvas.
- Del is the keystroke shortcut for this command.

Constraints:

- At least one element must be selected in the active canvas.

5.23 Edit | Duplicate

Description:

- Duplicates the currently selected elements in the canvas.
- CTRL+M is the keystroke shortcut for this command.

Constraints:

- At least one element must be selected in the active canvas.

5.24 Edit | Extract

Description:

- Extracts the selection to a new model and displays it in a new canvas.
- This command has the same result as the sequence of commands: Edit | Copy, File | New and Edit | Paste.

Constraints:

- At least one element must be selected in the active canvas.

5.25 Edit | Find

Description:

- Opens the **Edit | Find** dialog where you can specify the text to search for in the canvas
- CTRL+F is the keystroke shortcut for this command.

Constraints:

- At least one canvas window must be opened in the workspace.

5.26 Edit | Select All

Description:

- Selects all visible objects in the active canvas.
- CTRL+A is the keystroke shortcut for this command.

Constraints:

- At least one canvas window must be opened in the workspace.

5.27 Edit | Select None

Description:

- Deselects all elements in the active canvas
- Shift+CTRL+A is the keystroke shortcut for this command.

Constraints:

- At least one canvas window must be opened in the workspace.

5.28 Edit | Select Inverse

Description:

- Inverts the selection in the active canvas.
- CTRL+I is the keystroke shortcut for this command.

Constraints:

- The command is disabled if the active canvas is empty.

5.29 Edit | Align To Grid

Description:

- Aligns selected elements to the grid.
- See also the related commands: [View | Show Grid](#) and [View | Grid Size](#)
- CTRL+Shift+R is the keystroke shortcut for this command.

Constraints:

- At least one element must be selected in the active canvas.

5.30 Edit | Align To

- Top
- Bottom
- Left
- Right
- Vertical
- Horizontal

Description:

- Aligns all the selected elements in one line to, respectively, the top-, bottom-, left- and rightmost element in the selection.
- *Align Vertical* and *Horizontal* position the selected elements along the vertical or horizontal line respectively, in the middle of the selection area.
- *Align to Top* and *Align to Bottom* command place all selected elements in one horizontal line. *Align to Left* and *Align to Right* command place all selected elements in one vertical line.

Constraints:

- At least two elements must be selected.

5.31 Edit | Move To

- Top
- Bottom
- Left
- Right
- Top (1px)
- Bottom (1px)
- Left (1px)
- Right (1px)

Description:

- Moves all selected elements to the top, bottom, left or right.
- The user has the choices to translate the elements by one pixel (1px) or by one grid element, which is the number of pixels defined in grid size
- The key strokes displayed next to the menu items are useful short-cuts to speed up multiple move operations

Constraints:

- At least one element must be selected.

5.32 Edit | Insert Entity

- Continuous
- Discrete
- Generic

Description:

- Inserts an entity into the active canvas.
- The new entity is positioned in the center of the visible area of the canvas.

Constraints:

- At least one canvas is opened in the workspace.

5.33 Edit | Insert Process

- Continuous
- Discrete
- Generic

Description:

- Insert a process into the active canvas.
- The new process is positioned in the center of the visible area of the canvas.

Constraints:

- At least one canvas window must be opened in the workspace.

5.34 Edit | Insert Image

Description:

- Inserts an image in a JPEG, GIF, or PNG file into the active canvas. SVG (Scalable Vector Graphics) images can also be inserted.
- In the File Open dialog you can select the file name and type (Image File or SVG Image File) of the image to be inserted. The option *Save Internally* specifies whether the image should be saved internally - inside the model CSML file, or externally – as a reference to an external graphics file.
- The new image is positioned in the center of the visible area of the canvas.

Constraints:

- At least one canvas window must be opened in the workspace.

5.35 Edit | Insert Text

Description:

- Inserts an empty text box into the active canvas.
- Double-click the text box and enter text from the keyboard.
- The new text box is positioned in the center of the visible area of the canvas.

Constraints:

- At least one canvas window must be opened in the workspace.

5.36 Edit | Insert Frame

Description:

- Inserts a rectangular frame into the active canvas.
- The new frame is positioned in the center of the visible area of the canvas.

Constraints:

- At least one canvas window must be opened in the workspace.

5.37 Element | Show All

Description:

- Shows all elements in the active canvas.
- It will show all hidden elements by changing their *Visible* flag to true.
- This command is useful since hidden element cannot be selected on the canvas
- The other way to make element visible is to edit their *Visible* property in *Element Lists* frame.

Constraints:

- At least one canvas window must be opened in the workspace.

5.38 Element | Hide

Description:

- Hides the selected elements on the active canvas.
- Hidden element cannot be selected cannot be selected on the canvas
- To make the hidden elements visible, either execute the **Element | Show All** or change the *Visible* flag in *Element Lists* frame

Constraints:

- At least one element must be selected in the active canvas.

5.39 Element | Element Type

- Continuous
- Discrete
- Generic

Description:

- Sets the type of the selected entities and processes
- Note that not all type combinations of connected processes, entities and connectors are valid. Observe the connection rules specified in the User Guide.
- The element type and other properties can be viewed/edited in Element Settings frame in more detailed way.

Constraints:

- At least one entity or process must be selected.

5.40 Element | Connector Type

- Process
- Inhibitory
- Association

Description:

- Sets the type of the selected connectors
- Note that not all type combinations of connected processes, entities and connectors are valid. Observe the connection rules specified in the User Guide.
- The element type and other properties can be viewed/edited in Element Settings frame in more detailed way.

Constraints:

- At least one connector must be selected.

5.41 Element | Reverse Direction**Description:**

- Reverses the edge direction.
- For association and inhibitor connectors the direction is not changed

Constraints:

- At least one edge must be selected.

5.42 Element | Arrange

- Bring to Front
- Bring Forward
- Send Backward
- Send to Back

Description:

- With this set of commands, you can set the depth of overlapping figures in the canvas. Depth defines the way in which overlapping figures are displayed. A figure with a lower depth value is displayed over a figure with a higher depth value.
- The depth value of each figure can be viewed and edited in [Element Settings](#) frame.
- *Bring Forward* decreases the depth value of the selected figures by one.
- *Send Backward* increases the depth value of the selected figures by one.
- *Bring to Front* shows the selected figure at the front. This function sets depth to value which is smaller one degree than the smallest depth value in bounds of this figure on canvas.
- *Send to Back* hides the selected figure behind the other figures. This function sets depth to value which is greater one degree than the greatest depth value in bounds of this figure on canvas.
-

Constraints:

- At least one element must be selected in the active canvas.

5.43 Element | Group**Description:**

- Assembles two or more selected elements into a single group element.
- A group can be moved or edited as one element.

Constraints:

- At least two elements must be selected in the active canvas.

5.44 Element | Ungroup

Description:

- Disassembles a selected group into individual elements.

Constraints:

- At least one group element must be selected in the active canvas

5.45 Element | Size

Description:

- Sets the size of selected figures

Constraints:

- At least one figure must be selected in the active canvas.

5.46 Element | Fill Color

Description:

- Fills the inside of selected figures with the specified color.

Constraints:

- At least one figure must be selected in the active canvas.

5.47 Element | Line Color

Description:

- Sets the line color of a selected figure to a color from the list.

Constraints:

- At least one figure must be selected in the active canvas.

5.48 Element | Line Style

- Straight
- Curve Bezier

→ Curve Spline

Description:

- Sets the line style of the selected connectors. The user may choose between straight and curved lines.

Constraints:

- At least one connector must be selected in the active canvas.

5.49 Element | Stroke

Description:

- Sets the stroke (line pattern) of selected figures to a pattern from the list of available patterns.
- The user can define his own pattern using option *Custom*. In that case a dialog box for define pattern will appear.
- This menu option cannot change stroke for connector end (for example arrow stroke). To change stroke of connector end user should use element settings frame.

Constraints:

- At least one figure must be selected in the active canvas.

5.50 Element | Remove All Anchors

Description:

- Transforms broken-line edges selected in the canvas into straight line by removing all anchor points.
- If a line is broken in several places (with several anchors), all anchor points will be removed.

Constraints:

- At least one edge line must be selected.

5.51 Element | Set Image

Description:

- For one element in the canvas, the command replaces its figure with the figure from an image file.

- This operation changes the look of an element only; It has no impact on simulation results

Constraints:

- Exactly one element must be selected in the active canvas.

5.52 Element | Set Image Type

Description:

- For all selected element in the canvas, the command sets its figure type to *internal* or *external*.
- Internal images are saved inside the CSML file, while for external – the path to an external graphics files is saved in CSML

Constraints:

- At least one element must be selected in the active canvas.

5.53 Element | Edit Image

Description:

- Opens the editor for the selected image.
- SVG files are edited by the GLIPS Graffiti SVG editor, which is an integral part of CI package.
- Other files, JPEG, PNG, and GIFF are edited by the default graphics editor that is associated with the PNG extension of your Windows or Mac OS. On Linux platform the default graphics editor is gimp.
- Standard CI images, e.g. process, entity or connector images cannot be edited. Only images inserted into the canvas from user files can be edited. To insert an image use the commands: Element | Set Image.

Constraints:

- Exactly one editable image must be selected. Editable images are images saved in external or internal image files: JPEG, PNG, GIF or SVG files.

5.54 Element | Resize Image

- ➔ Fit to Current Width
- ➔ Fit to Current Height
- ➔ Original Size

Description:

- Resizes each selected image to its original size/ratio using 3 methods:
 - o Keep current width and adjust height
 - o Keep current height and adjust width
 - o Change width and height to its original value
- Every bitmap image (JPEG, PNG, and GIFF) or SVG image has its original size: width and height. The width/height relation defines the image *ratio*. Displaying images in original size assures the best quality. Also good quality can be achieved when keeping the original *ratio*. Resizing the image without keeping the *ratio* is possible however it may lower the image quality.
- This command allows to improve the image quality by reverting to its original *ratio* or size

Constraints:

- At least one image must be selected.

5.55 Element | Edit Chemical Structure

Description:

- Opens the *Chemical Structure Editor* for the selected entity.
- In the Cell System Ontology (CSO), the biological property *Chemical Structure* is meaningful for the CSO Class *SmallMolecule* only. If the edited vertex has a different CSO Class, you will be asked whether he wants to change the CSO Class to *SmallMolecule*.
- You may replace the current entity image by the SVG image of the created/edited chemical structure. For this select the *Replace SVG Image* checkbox, when closing the *Chemical Structure Editor*,

Constraints:

- Exactly one entity must be selected.

5.56 Element | References

Description:

- Displays the list of external references in a popup menu. Choose an item from the pop up menu to open the URL in a Web Browser window.
- *External References* menu item opens the **External References** frame where you can view and manage the list of references associated with the selected element.
- References define links from the selected element to external resources specified as URLs. Reference may define a link from the selected element to a database element, such as an entry in a database or a term in a controlled vocabulary.

- URL References can be associated to all elements: entities, processes, connectors.

Constraints:

- Exactly one element is selected in the active canvas.

5.57 Element | URL Templates

Description:

- Displays the list of URL templates available for this element.
- Choose a link from the list to open the URL in a Web Browser window.
- The URL templates are associated to all elements: entities, processes, connectors. You can view/edit the list of predefined URL templates in the *Hyperlink Templates* section in the **Preferences** dialog

Constraints:

- Exactly one element is selected in the active canvas.

5.58 Element | Label

- Fill Color
- Line Color
- Stroke
- Font

Description:

- The Fill Color command sets the text background color for all labels of the selected elements.
- The Line Color command sets the label border color.
- The Stroke command sets the label border pattern.
- The Font command sets the label font style.

Constraints:

- At least one item must be selected in the active canvas.

5.59 Element | Show Name

- On
- Off

Description:

- Shows or hides, respectively, names of all selected elements.

Constraints:

- At least one element must be selected in the active canvas.

5.60 Element | Show Variable

- On
- Off

Description:

- Shows or hides, respectively, the variable name for all selected elements

Constraints:

- At least one element must be selected in the active canvas.

5.61 Element | Show Value

- On
- Off

Description:

- Shows or hides the value labels of selected elements

Constraints:

- At least one element must be selected in the active canvas.

5.62 Element | Show Firing Style

- On
- Off

Description:

- Shows or hides the firing style of the selected elements. The firing style is the property of process elements.

Constraints:

- At least one element must be selected in the active canvas.

5.63 Element | Log

- ➔ On
- ➔ Off

Description:

- Switches on/off the log property of the selected elements.

Constraints:

- At least one element must be selected in the canvas.

5.64 Element | Create Chart

Description:

- Creates a new chart for the entities, processes and connectors that are selected in the canvas window.
- The list of charts can be viewed and controlled in the [Chart Settings](#) frame

Constraints:

- At least one element must be selected in the canvas.

5.65 Element | Update Location

Description:

- For selected elements, sets their Cell Component property to the value of underlying/overlapping cell component.

Constraints:

- At least one element must be selected in the canvas.

5.66 Simulation | Play

Description:

- If the model in the active canvas is in the “initialized” or “paused” state, the command starts the simulation.
- The accuracy and length of simulation are controlled by the *Sampling interval* and the *Simulation time* which are properties of the model. You can set these and all other parameters in the [Simulation Settings](#) frame.

- For a new canvas, the *Sampling Interval*, *Simulation Time* and all other simulation settings *are* initialized on the base of user preference settings. See **Preferences** dialog for more details.
- The speed of simulation corresponds to the *Speed* setting in the **Simulation Settings** frame. By default it is 1, which is 1 Petri Net time per 1 second. Increasing the *Speed* parameter speed up the simulation execution proportionally. However, it is limited by the hardware on which the program runs.
- Process firing and changes of entity values are shown in the canvas during the simulation. The *Canvas Update Interval* defines how often the canvas is updated.
- The status of a simulation run is displayed on the progress bar at the top of the active canvas.
- If there are any charts defined for the model, they are opened when the command is executed. The charts are periodically updated as the simulation runs. The update time is defined by the *Chart Update Interval*.
- The simulation stops when: (1) the user has executed the **Simulation | Stop And Initialize** command, or (2) the user has executed the **Simulation | Pause** command, or (3) the simulation time has reached the value specified (in pt units) by the *Simulation time* setting in the Simulation Settings frame.

Constraints:

- At least one canvas is opened in the workspace
- The model in the active canvas is not in the “simulation end” state

5.67 Simulation | Step Play

Description:

- The command executes one simulation step for the model in the active canvas.
- One step corresponds to 1 *Sampling Interval* in Petri net time units. The *Sampling interval* is a property of the active model and it is displayed in the **Simulation Settings** frame.
- For a new canvas, the *Sampling interval* is initialized on the base of the user preference settings. See **Preferences** dialog for more details.
- The *Speed* setting and the *Simulation time* is ignored for this command.
- The simulation status is displayed at the top of the CI canvas.

Constraints:

- At least one canvas is opened in the workspace

5.68 Simulation | Pause

Description:

- Pauses a running simulation.
- The simulation can be resumed with the **Simulation | Play** and other play commands: *Step Play*, *Fast Play*, *Max Speed Play*.

Constraints:

- The command is disabled if no simulation is running.

5.69 Simulation | Stop And Initialize

Description:

- If there is a running simulation, it is stopped and initialized
- Variables associated with entities are reset to their initial values.

Constraints:

- The command is enabled if a simulation for the model in the active canvas has been paused or completed.

5.70 Simulation | Fast Play

Description:

- Starts the simulation in fast mode for the model in the active canvas. The command behaves like **Simulation | Play** but the simulation execution is 10 times faster.
- The simulation speed is limited by the hardware on which the program runs.
- The charts are updated rarely in comparison to *Play* mode.
- The canvas updates normally – in the same way as in *Play* mode.
- Before starting a *fast* simulation run, it is recommended convert all *Pnuts* scripts to in *Java* or *simplemath*, because the evaluation of scripts written in *Pnuts* is much slower than of scripts written in *Java* or *simplemath*.
- If the active model includes *Pnuts* scripts, a simulation warning dialog box will be displayed with the list of all detected *Pnuts* scripts. Using this dialog box you may convert all *Pnuts* scripts to *Java* or *simplemath*.

5.71 Simulation | Max Speed Play

Description:

- Starts the simulation in the fastest mode. The command behaves like **Simulation | Fast Play** but the simulation is executed as fast as possible

- The speed of the simulation is the highest possible speed given by the hardware limits. The canvas is not updated during simulation and charts are updated very rarely.
- Before starting a *fast* simulation run, it is recommended convert all *Pnuts* scripts to in *Java* or *simplemath*, because the evaluation of scripts written in *Pnuts* is much slower than of scripts written in *Java* or *simplemath*.
- If the active model includes *Pnuts* scripts, a simulation warning dialog box will be displayed with the list of all detected *Pnuts* scripts. Using this dialog box you may convert all *Pnuts* scripts to *Java* or *simplemath*.

5.72 Simulation | Run Reference Simulation

Description:

- Starts a *reference simulation*. During this simulation the entity values are set from the external file.
- At the start of the simulation, the **Reference Simulation** dialog box is displayed. In this dialog the user specifies the CSV data file with time series of values (format similar to Cell Illustrator CSV simulation log) and other options.

Constraints:

- The file must be chosen and it must be a proper CSV file

5.73 Simulation | Run Parameterized Simulation

Description:

- Starts a series of SECG simulations in the bulk mode
- Allows specifying some entities as parameters (their start value will change in different simulations)
- For each parameter a value range is specified (the smallest/starting and the biggest possible value of the entity is selected, as well as description how the values should differ from each other). The parameters are set in the **SECG Passing Parameters** dialog
- Runs simulation for each combination of parameter values
- Long simulations can be canceled
- The view of the simulation results is controllable by the **Parameterized Simulation Results**

Constraints:

- At least one parameter must be selected

5.74 View | Mode

- None
- View
- Edit
- Simulation
- All
- Custom

Description:

- This command sets the global *mode* of displaying labels. Changing the *View Mode* causes that specific information is not displayed on the canvas and that selected labels are always hidden.
- To see the details of global label view settings, open the **View Settings** frame.
- The *Custom* view mode can be defined by the user in the **View Settings** frame.
- This command is a short-cut that allows for changing the view setting for several label types at once.
- Depending on the selected *View Mode*, selected labels of entities, processes, connectors or fact edges are always hidden, e.g. after *View | Mode | None* command all labels will be hidden. In the other view modes only the less important labels are hidden, e.g. after *View | Mode | View* all simulation-related labels will be hidden. After *View | Mode | All*, all labels are shown.
- The *View Mode* setting is global. It applies to all canvases in the workspace.

Constraints:

- None

5.75 View | Zoom In

Description:

- The command brings a virtual camera closer to the model in the active canvas
- If necessary, the command will enlarge the canvas by increasing its width and/or height.
- **View | Actual Size**, reverts the canvas to its original scale and size.

Constraints:

- At least one canvas window must be opened in the workspace.

5.76 View | Zoom Out

Description:

- The command brings a virtual camera farther from the model in the active canvas window.
- **View | Actual Size** reverts the canvas to its original scale

Constraints:

- At least one canvas window must be opened in the workspace.

5.77 View | Actual Size**Description:**

- The command moves the virtual camera so that the canvas is displayed with its actual size.
- If necessary, the command will shrink the canvas by decreasing its width and/or height.

Constraints:

- At least one canvas window must be opened in the workspace.

5.78 View | Fit In Canvas**Description:**

- If one or more elements are selected, the command scrolls and zooms the graph in the window to display the selected elements in the canvas.
- Otherwise, the virtual camera is moved to fit the display of all elements in the active window.
- If necessary, the command will enlarge the canvas by increasing its width and/or height.
- [View | Actual Size](#) reverts the canvas to its original scale and size

Constraints:

- At least one canvas window must be opened in the workspace.

5.79 View | Duplicate Canvas**Description:**

- Creates a new *Canvas Window* for the active model.
- Initially the new canvas is identical to the original one. However changes of view attributes (element visibility, colors, sizes, location, images, etc.) will apply to the selected canvas only, so that the duplicated canvas will differ from the original one.
- You can open several canvas windows to view different parts of the model or to view the same model in a different way.

Constraints:

- At least one canvas window must be opened in the workspace.

5.80 View | Delete Canvas

Description:

- Deletes the active *Canvas Window* for the active model.
- This operation is opposite of View | Duplicate Canvas

Constraints:

- At least two canvas window must exist for the active model.

5.81 View | Show All Charts

Description:

- Opens all charts defined for the active canvas

Constraints:

- At least one canvas window must be opened in the workspace.

5.82 View | Hide All Charts

Description:

- Closes all charts defined for the active canvas

Constraints:

- At least one canvas window must be opened in the workspace.

5.83 View | Show Grid

Description:

- Toggles the grid display on and off for the active canvas window.
- If grid is on, entities are aligned to the grid automatically, when they are inserted or moved.
- If the grid is off, the entities are moved and inserted freely without grid alignment
- Changing the grid size ([View | Grid Size](#)) may disturb the alignment. In such a situation, the elements can be aligned using this command [Edit | Align To Grid](#)

Constraints:

- At least one canvas window must be opened in the workspace.

5.84 View | Antialiasing**Description:**

- Toggles antialiasing on and off for the active canvas windows.
- With the antialiasing in the *on* state, model diagrams look better but it takes more time to draw them.

Constraints:

- At least one canvas window must be opened in the workspace.

5.85 View | Grid Size**Description:**

- Sets the grid size for the active canvas windows

Constraints:

- At least one canvas window must be opened in the workspace.

5.86 View | Background Color**Description:**

- Sets the background color for the active canvas window

Constraints:

- At least one canvas window must be opened in the workspace.

5.87 Analyze | Extract Subnet**Description:**

- Creates a new canvas with the selected elements from the active canvas.
- Selected edges are added to the new canvas if target and source vertex are added

Constraints:

- At least one element must be selected.

5.88 Analyze | Select | Downstream

Description:

- Extends the current selection in the canvas by children of the selected entities

Constraints:

- At least one element must be selected in the active canvas.

5.89 Analyze | Select | Upstream

Description:

- Extends the current selection in the canvas by parents of the currently selected entities

Constraints:

- At least one element must be selected in the active canvas.

5.90 Analyze | Select | Both

Description:

- Extends the current selection in the canvas by selecting children and parents the currently selected genes

Constraints:

- At least one entity must be selected in the active canvas.

5.91 Analyze | Keyword Search

Description:

- Opens the **Keyword Search** dialog where you can specify the text to search for in the canvas
- CTRL+F is the keystroke shortcut for this command.

Constraints:

- At least one canvas window must be opened in the workspace.

5.92 Analyze | Path Search

Description:

- Opens the **Path Search** dialog, where you can search for closest neighbors of the selected entity or perform start-to-end path search

Constraints:

- At least one canvas window must be opened in the workspace.

5.93 Analyze | Entity List Search

Description:

- Opens the **Entity List Search** dialog where you can search for a given list of entities.

Constraints:

- At least one canvas window must be opened in the workspace.

5.94 Analyze | Compare

Description:

- Compares (merges) two or more networks from the workspace.
- This operation compares selected networks and finds the common part of the networks (intersection), the differences between the networks and the sum of the networks (union).
- The active graph (*Main Graph*) is treated in a unique way during network merge: The graph elements in the intersection network and also common graph elements in the union network inherit their properties from corresponding elements from the *Main Graph*.
- The comparison results are displayed as new models arranged side by side in the tabbed pane:
 - Union of *Main Graph* and *Other networks*
 - Intersection of *Main Graph* and *Other networks*
 - Differences between *Main Graph* and *Other networks*
 - Differences between the union of *Other Networks* and *Main Graph*
- This command opens the **Compare** dialog box, in which the user specifies the comparison options.

Constraints:

- Two or more models must be opened in the workspace.

5.95 Analyze | Gene Mining

Description:

- Starts the gene mining search for the selected genes and displays the results in **Gene Mining** frame
- If nothing is selected the gene mining will be done for all elements in the active canvas
- The Gene Mining frame is always activated at the end of this command.
- If there is no gene database, it should be downloaded using **Analyze | Download Gene Mining Database**

Constraints:

- At least one canvas window must be opened in the workspace.
- The gene mining database must be available on the client computer

5.96 Analyze | Generate Gene References

Description:

- Starts the generation of external references for the selected genes.
- If nothing is selected the gene mining will be done for all elements in the active canvas
- The external references are generated by connecting element names with the Pubmed, OMIM and KEGG links from the gene database that is used for gene mining.
- The **External References** frame is always activated at the end of this command to show the results of this command. If nothing is selected, Select all elements in the canvas to see the results.
- The Gene Mining frame is always activated at the end of this command.
- If there is no gene database, it should be downloaded using **Analyze | Download Gene Mining Database**

Constraints:

- At least one canvas window must be opened in the workspace.
- The gene mining database must be available on the client computer

5.97 Analyze | Download Gene Mining Database

Description:

- Downloads the gene mining database to the local computer. If the database is already downloaded, checks if the database is up to date.

Constraints:

- Internet connection is required

5.98 Select | Upstream

- Vertex and Edge
- Vertex Only
- Edge Only

Description:

- Extends the current selection in the canvas by parents of the selected elements
- The sub-menu item - *Vertex and Edge*, *Vertex Only*, *Edge Only* – defines the type of the newly selected elements

Constraints:

- At least one element must be selected in the active canvas.

5.99 Select | Downstream

- Vertex and Edge
- Vertex Only
- Edge Only

Description:

- Extends the current selection in the canvas by children of the currently selected elements
- The sub-menu item - *Vertex and Edge*, *Vertex Only*, *Edge Only* – defines the type of the newly selected elements

Constraints:

- At least one element must be selected in the active canvas.

5.100 Select | Up- and Downstream

- Vertex and Edge
- Vertex Only
- Edge Only

Description:

- Extends the current selection in the canvas by selecting children and parents of the currently selected elements
- The sub-menu item - *Vertex and Edge*, *Vertex Only*, *Edge Only* – defines the type of the newly selected elements

Constraints:

- At least one entity must be selected in the active canvas.

5.101 Select | Inverse

- Entities
- Processes
- Entities and Processes
- Connectors
- Fact Edges
- Any Type

Description:

- Inverts the current selection in the canvas for the selected type of elements:
Entities, Processes, Entities and Processes, Connectors, Fact Edges, Any Type

Constraints:

- At least one element must be selected in the active canvas.

5.102 Select | All

- Entities
- Processes
- Entities and Processes
- Connectors
- Fact Edges
- Any Type

Description:

- Selects all elements of the given type - *Entities, Processes, Entities and Processes, Connectors, Fact Edges, Any Type* - in the active canvas

5.103 Select | None

- Entities
- Processes
- Entities and Processes
- Connectors
- Fact Edges
- Any Type

Description:

- Deselects all elements of the specified type - *Entities, Processes, Entities and Processes, Connectors, Fact Edges, Any Type* - in the active canvas

5.104 Window | Tile Horizontal

Description:

- Tiles the canvas windows horizontally.

Constraints:

- At least two models must be opened in the workspace.

5.105 Window | Tile Vertical

Description:

- Tiles the canvas windows vertically.

Constraints:

- At least two models must be opened in the workspace.

5.106 Window | Maximize Canvas

Description:

- Maximizes the canvas windows of the active model.
- It removes the split created by the Window | Tile commands.

Constraints:

- At least two models must be opened in the workspace.

5.107 Window | Open Perspective

- All
- Edit
- View
- Simulation

Description:

- This command sets the global *perspective* of Cell Illustrator. Changing the *perspective* causes that specific frames are displayed in the selected layout, while other, less useful, frames are hidden.
- By default, each perspective displays only those frames which are related to its name, e.g. in the perspective *Simulation* or *View*, only the frames related to simulation or view properties are displayed, in the *Edit* perspective, all frames important for editing are displayed, while for perspective *All*, all frames are displayed
- The default (initial) layout of each perspective can be changed by common window operation on the frames (show, hide, translate, etc.). The frame layout is saved upon exiting the application and restored at startup.
- To revert to the initial (default) layout, execute **Window | Reset Perspective**

Constraints:

- None

5.108 Window | Reset Perspective

Description:

- Resets the layout of the currently selected perspective by reverting to the initial (default) location, size, layout and visibility of all frames.

Constraints:

- None

5.109 Window | Show Frame

Description:

- Display and activate the selected frame.
- This command drops down the list of all frames available in Cell Illustrator.

Constraints:

- None

5.110 Window | Hide All Frames

Description:

- Hide all frames and display the canvas window in maximal size.

Constraints:

- None

5.111 Window | Restore All Frames

Description:

- Restore the frames which were hidden, e.g. by Window | Hide All Frames command or other user actions.

Constraints:

- None

5.112 Window | Preferences

Description:

- Opens the **Preferences** dialog box, in which the user can view/edit the global settings.

Constraints:

- None

5.113 Help | Cell Illustrator Help

Description:

- Opens the HTML help system for Cell Illustrator.

Constraints:

- Internet connection is required

5.114 Help | User Guide

Description:

- Downloads and opens the Cell Illustrator User Guide.

Constraints:

- The User Guide is a PDF document. Adobe Acrobat Reader or another software capable of reading PDF documents needs to be installed and configured on your machine.
- Cell Illustrator uses your default internet browser to open document so you have to be connected to the internet to download the User Guide.

Constraints:

- Internet connection is required

5.115 Help | Cell Illustrator Online

Description:

- Opens the CI Online web site in the default browser.

Constraints:

- The Internet connection must be available.

5.116 Help | CSML Online

Description:

- Opens the www.csml.org web site in the default browser.
- CSML (Cell System Modeling Language) is the XML file format and OWL ontology that is used in Cell Illustrator to store and exchange models.

Constraints:

- The Internet connection must be available.

5.117 Help | Cell Illustrator User Forum

Description:

- Opens the user forum web site in the default browser.

Constraints:

- The Internet connection must be available.

5.118 Help | About Cell Illustrator





Description:

- Displays the dialog [About Cell Illustrator](#) with the version and license information

6 Toolbars









6.1 Library Toolbar







This toolbar is located at the top of the main window and contains a set of buttons that connect to the libraries of biological elements, fragments and models to facilitate model building.



Icon	Button Name	Description
	Part Library	Opens the Parts Library frame
	Biological Elements	Opens Biological Elements frame
	CSMLDB Search	Opens CSMLDB Search frame
	Project Manager	Opens Project Manager frame
	Go To BioPACS	See BioPACS Library

6.2 Draw Toolbar

This toolbar is located at the top of the main window and contains a set of buttons for the most frequent edit operations.







Icon	Button Name	Description
	Selection Mode	In this mode, you can select elements on the canvas with the arrow cursor.
	Create Continuous Entity	Push this button and click on the active canvas to insert a continuous entity. Each subsequent click adds a new entity.
	Create Continuous Process	Push this button and click on the active canvas to insert a continuous process. Each subsequent click adds a new process.
	Create Discrete Entity	Push this button and click on the active canvas to insert a discrete entity.
	Create Discrete Process	Push this button and click on the active canvas to insert a discrete process.
	Create Generic Entity	Push this button and click on the active canvas to insert a generic entity.
	Create Generic Process	Push this button and click on the active canvas to insert a generic process.
	Create Process Connector	Push this button and draw a line between two elements on the active canvas to insert a process connector.
	Create Inhibitory Connector	Push this button and draw a line between two elements on the active canvas to insert an inhibitory connector

	Create Association Connector	Push this button and draw a line between two elements on the active canvas to insert an association connector
	Create Fact Edge	Push this button and draw a line between two entities on the active canvas to insert a fact edge.
	Create Frame	Push this button and drag the mouse cursor on the active canvas to insert a frame
	Create Note	Push this button and drag the mouse cursor on the active canvas to insert a text note.
	Insert Image	See Edit Insert Image
	View Style Paintbrush	Select the element whose view style you want to copy and push this button. With the View Style Paintbrush tool active, select elements on the canvas to apply the copied view properties. This operation is similar to the Edit Paste View Style
	Zoom In	Push this button and click on the active canvas to zoom in.
	Zoom Out	Push this button and click on the active canvas to zoom out.
	Reset Zoom	See View Actual Size
	Fit in Canvas	See View Fit In Canvas
	Toggle the Antialiasing Status	See View Antialiasing
	Toggle the Grid Visible Status	See View Show Grid
	Group	See Element Group
	Ungroup	See Element Ungroup
	Set View Mode	With this button, you can set global view mode. See View Mode
	Set Color	Changes fill color of selected elements. If connector is selected arrow fill color change

	Line Color	Changes line color of selected elements. If connector is selected arrow line color doesn't change
	Select Color Tool	With this button, you can select the Fill Color, Line Color or the Text Color as the current setting for the Set Color command
	Set Line Stroke	Sets line stroke of selected elements. If connector is selected arrow line stroke doesn't change



6.3 File Toolbar









This toolbar is located at the left side of the main window, above the Undo/Redo and Simulation toolbars. It consists of a set of buttons for file management operations.

Icon	Toggle Button	Name	Full Description
	No	Create New Canvas	See File New
	No	Open Canvas File	See File Open
	No	Close File	See File Close File
	No	Close All Files	See File Close All Files
	No	Save Active Canvas	See File Save
	No	Save Canvas To Selected File	See File Save As

6.4 Edit Toolbar









This toolbar is located at the left side of the main window, below the File Toolbar and above the Simulation Toolbar. It contains buttons for Undo/Redo and Align commands.

Icon	Name	Description
	Undo	See Edit Undo
	Redo	See Edit Redo

	Align Top	See Edit Align To
	Align Bottom	
	Align Left	
	Align Right	
	Align Vertical	
	Align Horizontal	
	Space Evenly Vertical	
	Space Evenly Horizontal	



6.5 Simulation Toolbar









This toolbar is located on the left side of the main window below the File Toolbar and Undo/Redo Toolbar. It contains buttons for starting and stopping simulation.

Icon	Name	Description
	Play Simulation	See Simulation Play Simulation Play
	Step Play simulation	See Simulation Step Play Simulation Step Play
	Pause Simulation	See Simulation Pause Simulation Pause
	Stop Simulation and Initialize	See Simulation Stop And Initialize Simulation Stop and Initialize
	Fast Play Simulation	See Simulation Fast Play Simulation Fast Play
	Max Speed Play Simulation	See Simulation Max Speed Play Simulation Max Speed Play
	Play with Animation	See Simulation Play with Animation
	Save Simulation Log	See Simulation Settings

6.6 Dialog Toolbar

This toolbar is located on the right side of the main window and contains buttons that open or recall property frames.

Icon	Name	Description
	Element Lists Frame.	See Element Lists frame
	Element Settings Frame	See Element Settings frame

	Biological Properties Frame	See Biological Properties frame
	External References Frame	See External References frame
	Navigator Frame	See Navigator frame
	View Settings Frame	See View Settings frame
	Chart Settings Frame	See Chart Settings frame
	Simulation Settings Frame	See Simulation Settings frame
	Simulation Errors Frame	See Simulation Errors frame
	Simulation History Frame	See Simulation History frame
	Graph Layout	See Graph Layout frame

7 Drawing Canvas

The canvas window is the place where you build a model. In addition to commands available in the Menu Bar and the toolbars, you can right click (CTRL click on a Macintosh) on the canvas or on a selected element in the canvas to access a popup menu customized to your selection.

Right click on an edge element adds/removes break-point for the edge line. Use CTRL+click to open the popup menus for edges.

During simulation, the canvas window is updated with entity value changes. In some simulation modes, processes that fire are marked with color and animated tokens move between entities.

You can customize the background color and other properties of your canvas windows by editing the Canvas section of the application global settings in the **Preferences** dialog. Simulation visualization options are defined in the Animation Options section.

7.1 Multiple Views

In Cell Illustrator one model can be displayed on multiple canvases, which are located side by side in a tabbed pane. Different views can be used to show the model in a different way or to view different parts of the model. To create a new view for the active model the command **View | Duplicate Canvas** should be used.

When working with multiple views, the user edit-operations can apply to:

- the active view only, when the operation applies to view-specific attributes, or
- all views of the active model, when the operation applies to model-specific attributes.

View-specific attributes are graphical properties, such as element visibility, selection, size, location, image, color, line style, font, while model-specific attributes are element name, simulation properties, biological properties, element connectivity.

Inserted elements are added to all views of the model; however they are visible in the active canvas only, while in the other canvases they are initially hidden. To make elements visible, execute **Element | Show All** command or change the *Visible* flag in *Element Lists* frame

7.2 Canvas Popup Menus

Selection	Popup Menu Item	Referenced Command
None (Canvas)	Find	Edit Find
	-----	-----
	Undo	Edit Undo
	Redo	Edit Redo
	-----	-----
	Select All	Edit Select All
	-----	-----
	Paste	Edit Paste
	-----	-----
	Insert Entity	Edit Insert Entity
	Insert Process	Edit Insert Process
	Insert Image	Edit Insert Image
	-----	-----
	Insert	File Insert
	-----	-----
	Background Color	View Background Color
	-----	-----
	Duplicate Canvas	View Duplicate Canvas
Delete Canvas	View Delete Canvas	
Single Element	Cut	Edit Cut
	Copy	Edit Copy
	Delete	Edit Delete
	Duplicate	Edit Duplicate
	-----	-----
	Ungroup	Element Ungroup
	-----	-----
	Arrange	Element Arrange
	Set Image	Element Set Image
	Edit Image	Element Edit Image
	Resize Image	Element Resize Image
	-----	-----
	Edit Chemical Structure	Element Edit Chemical Structure
	-----	-----
	Size	Element Size
	Fill Color	Element Fill Color
	Line Color	Element Line Color
	Stroke	Element Stroke
	-----	-----
	Select	Analyze Select Downstream Analyze Select Upstream Analyze Select Both
	-----	-----
	Create Chart	Element Create Chart
	-----	-----
References	Element References	

	URL Templates	Element URL Templates
Multiple	Cut	Edit Cut
	Copy	Edit Copy
	Delete	Edit Delete
	Duplicate	Edit Duplicate
	-----	-----
	Group	Element Group
	Ungroup	Element Ungroup
	-----	-----
	Align To	Edit Align To
	Arrange	Element Arrange
	Set Image	Element Set Image
	Edit Image	Element Edit Image
	Resize Image	Element Resize Image
	-----	-----
	Size	Element Size
	Fill Color	Element Fill Color
	Line Color	Element Line Color
	Stroke	Element Stroke
	-----	-----
	Select	Analyze Select Downstream Analyze Select Upstream Analyze Select Both
	-----	-----
Create Chart	Element Create Chart	
-----	-----	

8 Frames

8.1 Element Lists

For the model in the active canvas, this frame displays the elements together with their major properties in a table

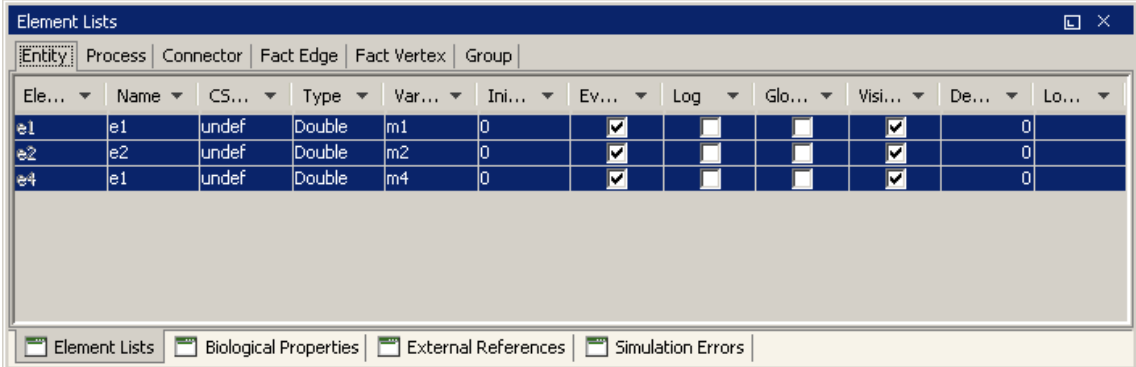

Ele...	Name	CS...	Type	Var...	Ini...	Ev...	Log	Glo...	Visi...	De...	Lo...
e1	e1	undef	Double	m1	0	<input checked="" type="checkbox"/>	<input type="checkbox"/>	<input type="checkbox"/>	<input checked="" type="checkbox"/>	<input type="checkbox"/>	0
e2	e2	undef	Double	m2	0	<input checked="" type="checkbox"/>	<input type="checkbox"/>	<input type="checkbox"/>	<input checked="" type="checkbox"/>	<input type="checkbox"/>	0
e4	e1	undef	Double	m4	0	<input checked="" type="checkbox"/>	<input type="checkbox"/>	<input type="checkbox"/>	<input checked="" type="checkbox"/>	<input type="checkbox"/>	0

The *Element Lists* frame consists of the tabbed tables *Entity*, *Process*, *Connector*, *Fact Edge*, *Fact Vertex* and *Group*.

The following operations can be done for each of the table:

- Select an element on the canvas by clicking on a row
- Sort rows according to the specified column by clicking on the column header,
- Filter rows by specified column by clicking on combo box on header of the column,
- Edit a given property by double clicking a cell
- Customize the visible column by right click on column header and choosing one of the menu items:
 - o Hide column
 - o Show All Hidden Columns
 - o Select Visible Columns
 - o Restore Default Columns

8.1.1 Entity Table

Each row in the table corresponds to an entity in the active canvas. The following properties are listed in the table:

- Element Id – unique identifier (not editable)
- Name – entity name
- CSO Class – Cell System Ontology Class
- Type – the value type of entity, *Integer* represent a discrete entity, *Double* – a continuous entity, *String* and *Boolean* – a generic entity, *Unknown* is a universal value.
- Variable – name of variable associated with the entity
- Initial Value – initial value or script for simulation
- Eval Once – tells whether the Initial Value script is evaluated only once at the simulation start up, or many times at each simulation step
- Max Value – maximum value of the entity during simulation
- Min Value – minimum value of the entity during simulation
- Log – if the box is checked the entity is included in a simulation log. The logged values can be viewed and analyzed in Simulation History Frame or exported to a CSV file.
- Global – by default for normal entities this flag is false. If the Flag is true, the entity is global. Global entities are used to represent cell biological compartments, containers for normal entities, such as cell components. The global entities cannot be connected to any process using connectors.
- Visible – toggles element visibility on the canvas.
- Show Name – toggles visibility of name label on the canvas.
- Show Variable – toggles visibility of variable label on the canvas.
- Show Value – toggles visibility of value label on the canvas.
- Show Biological Property – toggles visibility of biological property label on the canvas.
- Depth – changes how deep will be the entity painted.
- Location – biological location of the entity.
- GO, PubMed - display database IDs defined in external references (read-only)
- TRANSFAC, TRANSPATH – display Transpath database ID defined in external references (read-only)

8.1.2 Process Table

Each row in the table corresponds to a process in the active canvas. The following process properties are listed in the table:

- Element Id – unique identifier (not editable)
- Name – process name.
- CSO Class – Cell System Ontology Class, e.g.: biological process
- Type – discrete, continuous or generic.
- Calc Style – The meaning of the Calc Style depends on the process type. The *Speed* property is for a continuous process, for a discrete process – the *Add* property and for generic process – the *Update*.
- Firing Style – determines the firing style of the process. For “*And*” style, the process fires if all input connectors fulfill the firing condition. The “*Or*” firing style can be used if the process has two or more input

connectors of type *Inhibitor* or *Association*. For the “*Or*” firing style at least one *Inhibitor* or *Association* connector must fulfill the firing condition in order to the process to be enabled. Additionally \, all input *Process* connectors must be enabled.

- Kinetic Style –
- Kinetic Script – a value of script that defines how to calculate the value change in each simulation step.
- Delay Script – defines delay parameter.
- Activity – if the Activity is set to *false* a process does not fire. The Activity can be defined by mathematical formula.
- Priority – priority of the process used during simulation. Process with higher priority fires before a process with lower priority.
- Log – if the box is checked the process state is included in simulation log. You can see simulation log in Simulation History frame or export it to a CVS file.
- Activity Log –
- Visible – toggles visibility of the element.
- Show Name – toggles visibility of name label on the canvas.
- Show Speed – toggles visibility of speed label on the canvas.
- Show Delay – toggles visibility of delay label on the canvas.
- Show Firing Style – toggles visibility of firing style label on the canvas.
- Show Biological Property – toggles visibility of biological property label on the canvas.
- Depth – changes how deep will be the entity painted.
- Location – biological location of the process.
- Biological Process – defines which process in real cell is represented by this element.
- GO, PubMed - display database IDs defined in external references (read-only)
- TRANSFAC, TRANSPATH – display Transpath database ID defined in external references (read-only)

8.1.3 Connector Table

Each row in the table corresponds to a connector in the active canvas. The following connector properties are listed in the table:

- Element Id – unique identifier (not editable)
- Name – connector name.
- CSO Class – Cell System Ontology Class.
- Type – process, inhibitory or association.
- From – the input element (entity or process) of the connector.
- To - the output element (entity or process) of the connector.
- Kinetic Script – a value of script that defines how to calculate the value change in each simulation step.
- Firing Style – the firing style of the connector.
- Firing Script – the script or value that defines the firing condition.

- Log - if the box is checked the connector state is included in simulation log. You can see simulation log in Simulation History frame or export it to a CVS file.
- Visible – toggles element visibility.
- Show Name – toggles visibility of name label on the canvas.
- Show Firing Operation – toggles visibility of firing operation label on the canvas.
- Show Firing Style – toggles visibility of firing style label on the canvas.
- Depth – changes how deep will be the entity painted.
- Line Style – changes style of connector line. You can choose between:
 - Straight,
 - Curve Bezier,
 - Curve Spline.

8.1.4 Fact Edge

Each row in the table corresponds to a Fact Edge in the active canvas. The following properties are listed in the table:

- Element Id – unique identifier (not editable)
- Name –fact edge name.
- Parent – parent entity (source of the edge)
- Child – child entity (target of the edge)
- Type – directed or undirected relation.
- Relation Type – one of the predefined types of relation in gene nets.
- Comments – doesn't need explanation ☺
- Visible – toggles visibility of selected element
- Show Name – toggles visibility of name label on the canvas.
- Show Biological Property – toggles visibility of biological property
- Depth – changes how deep will be the entity painted.
- GO, PubMed - display database IDs defined in external references (read-only)
- TRANSFAC, TRANSPATH – display Transpath database ID defined in external references (read-only)

8.1.5 Fact Vertex

Each row in the table corresponds to a Fact Vertex in the active canvas. The following properties are listed in the table:

- Element Id – not editable identifier.
- Text – if vertex is a text field you can change text here.
- CSO Class – Cell System Ontology Class.
- Visible – toggles visibility of selected element.
- Depth – changes how deep will be the entity painted.

8.1.6 Group

Each row in the table corresponds to a connector in the active canvas. The following connector properties are listed in the table:

- Element Id – not editable identifier.
- Name – connector name.

- Visible – toggles visibility of selected element.
- Entity/Process/Connector/Fact Edge/Fact Vertex/Group Count – the number of elements of given type that are in the group
- Depth – changes how deep will be the entity painted

8.2 Element Settings

The *Element Settings* frame allows viewing and setting of properties of a selected element:

- If exactly one element is selected, the frame displays its properties. If more than one element is selected, the frame displays the *Multiple Selection* frame. Otherwise the frame shows global properties of the model in the active canvas.

Selection	Frame	Description
Single Selection: Exactly one element is selected	Element Settings frame. Depending on the type of selected element it displays the property sheet for: Entity, Process, Connector, Fact Vertex, Fact Edge, Group.	The Single Selection frames give the user the ability to view and edit the property values for the selected element
Multiple Selection: more than one element is selected	Multiple Selection frame: displays common view and biological properties for the selected elements	The Multiple Selection frames give the user the ability to view and edit the property values for several selected elements at once
Empty Selection	Model and Canvas Property Sheet	

- Change of selection or switching between canvas frames results in an update of the frame.
- Changing a setting in the frame has an immediate effect in the model.
- For models with multiple views, the view properties of the element in the active canvas are displayed or edited, e.g. the change of color will be shown in the active view only, while other views will remain unchanged.

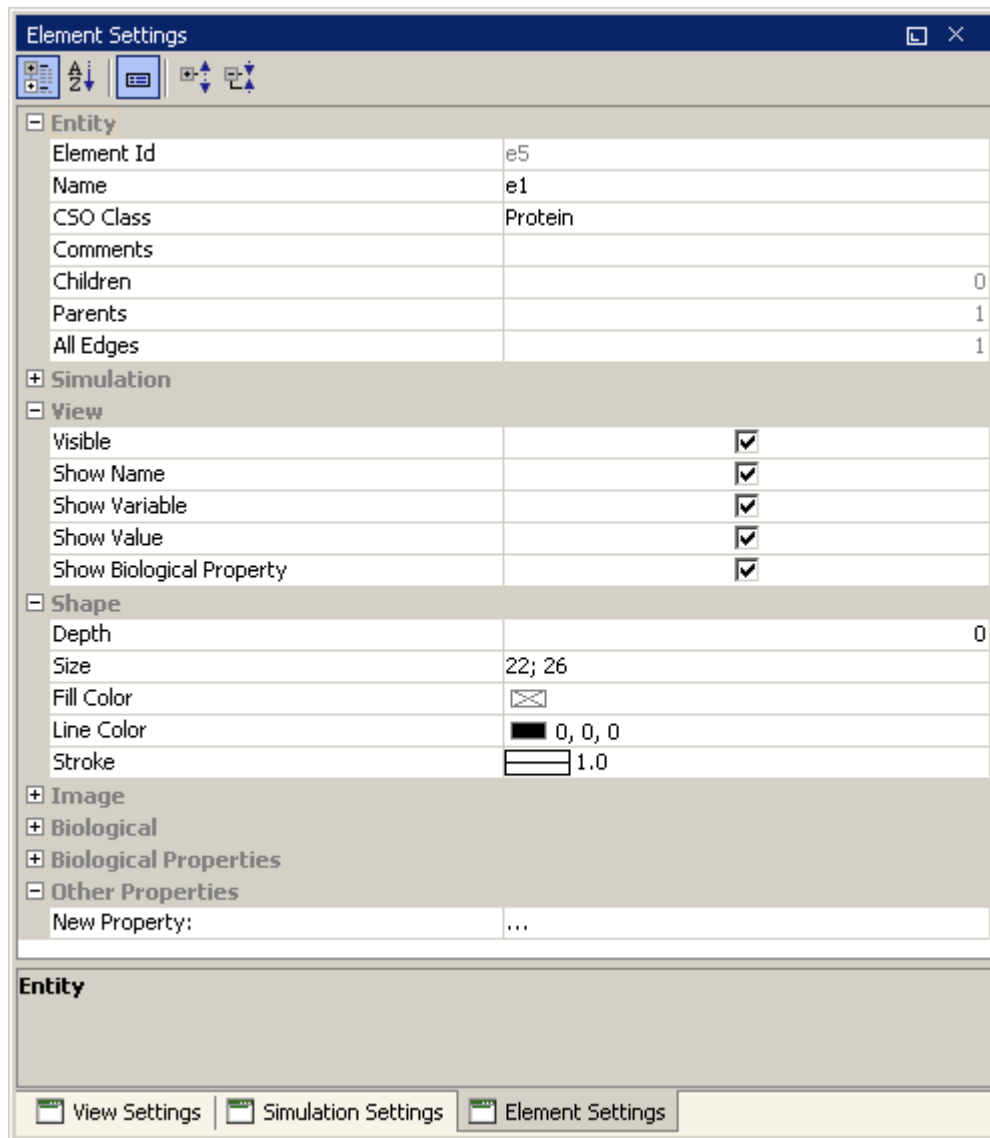

Most of the properties are self-explanatory and are already described in Element List frame. Therefore only the non-trivial properties will be described in this chapter including:

- Simulation Settings
- Biological Properties
- Custom Biological Properties
- Model and Canvas Properties
- Multiple Selection Frame

8.2.1 Simulation Section

The Element Settings frame allows the setting of mathematical formulas as element properties to define dependencies between elements during the simulation. The mathematical formulas can be set for specific entity, process or connector properties with the help of the [Script Editor](#).

8.2.1.1 Entity

Property Name	Description
Type	The <i>Double</i> type is associated with continuous entities, <i>Integer</i> with discrete entities, the other value types: <i>Boolean</i> and <i>String</i> with generic entities.
Variable	Name of variable associated with the entity
Initial Value	The value of the entity at the simulation startup. The property can be a fixed value or a script. If it is a script, it can be evaluated only at simulation startup (normal case), or at each simulation step (special case) - see <i>Evaluate Script Once</i> . The right, drop-down button allows for the definition of the mathematical formula within the Script Editor .
Eval Once	This property is ignored if the <i>Initial Value</i> is a fixed value. Otherwise, if the <i>Initial Value</i> is a script, there are 2 possibilities: <ul style="list-style-type: none"> • If the property is <i>on</i>, the <i>Value</i> property is initialized with value set by the script at the beginning of simulation. • If the property is <i>off</i>, the <i>Value</i> property is set by evaluating the script at each simulation step
Max Value	The maximum value that can be assigned to the variable associated with the entity. It can be 1, <i>infinite</i> or any other value entered by the user. This entry is enabled only for scalar value types: <i>Integer</i> , <i>Long</i> or <i>Double</i> .
Min Value	
Log	Tells, whether to log the entity values during simulation
Global	Tells, whether this entity is global. Global entities cannot be connected with connectors.

8.2.1.2 Process

Property Name	Description
---------------	-------------

<p style="text-align: center;">Calc Style</p>	<p>Determines how the variables in the connected entities are modified when the process fires. The following operations (calculation styles) can be specified:</p> <ul style="list-style-type: none"> • <i>Speed</i> – the process defines the speed of production or consumption of the entities. Speed determines the continuous process type. • <i>Add</i> – the process calculates the concrete values that should be added (subtracted) to the entities. Add determines the Discrete process type. • <i>Update</i> – the process calculates a concrete value that will replace the entity value. Update determines the Generic process type. <p>Note: The <i>Update</i> and <i>Add</i> calculation styles are time independent. Thus it is recommended that they be used in conjunction with a <i>Delay</i> value. This will assure that the process fires at a constant time interval and makes the simulation results independent of the sampling interval.</p>
<p style="text-align: center;">Firing Style</p>	<p>Determines how the enabled/disabled state of the process is calculated. The following styles can be selected from the drop-down list:</p> <ul style="list-style-type: none"> • <i>And</i> – All connected input connectors must fulfill their conditions to enable the process. • <i>Or</i> – At least one <i>Inhibitor</i> or <i>Association</i> input connector must fulfill its condition to enable the process. Additionally, all <i>Process</i> input connectors must fulfill their conditions.

Kinetic Style	<p>The following values can be selected from the drop down list:</p> <ul style="list-style-type: none"> • <i>Custom</i> • <i>Connector Custom</i> • <i>Connector Rate</i> • <i>Mass</i> • <i>Stochastic Mass</i> • <i>Michaelis Mentens</i> • <i>MM</i> • <i>Stochastic Log Normal Mass</i> <p>Each kinetic style requires different parameters. These parameters can be specified below Kinetic Script property:</p> <ul style="list-style-type: none"> - <i>coefficient1, coefficient2,</i> - <i>variance,</i> - <i>rate,</i> - <i>connector stoichiometry,</i> - <i>speed/add/update</i> - <i>connector speed/add/update.</i> <p>Only the parameter fields that are meaningful for the selected kinetic style are displayed.</p>
Kinetic Script	This is not editable property which is generated automatically using kinetic style property and parameters which are displayed below (as a sub tree) this property.
Delay Script	For discrete and generic processes, if the delay time $T > 0$, then the process fires just after the delay time T if it is still active. Otherwise, it can lose its chance to fire. If the delay time $T = 0$, the process fires immediately when it is possible. For continuous processes, there is no delay; The process fires immediately when the enabling conditions become true and its Activity property is set to <i>true</i> .
Activity	If the property is set to <i>false</i> , the process does not fire. The button allows for the definition of the mathematical formula within the Script Editor .
Priority	Sets the priority of the process during simulation. If two processes P1 and P2 with equal priority fire at the time t , the order of firing P1 and P2 is random. But if the priority of P1 is larger than P2, then P1 always fires before P2.
Log	
Activity Log	

8.2.1.3 Connector

Property Name	Description
Kinetic Script	
Firing Style	<p>Specifies the way, and how to calculate the firing activity of the connector. The Firing Style can take one of the following values:</p> <ul style="list-style-type: none"> - Threshold - Rule - No Check
Firing Script	<p>Depending on the <i>Firing Style</i>, this script can define either the <i>Firing Threshold</i> or the <i>Firing Rule</i>.</p> <p><i>Firing Threshold</i> The Threshold should be used for input connectors to discrete or continuous entities. The Threshold is a real value or a script that returns real value. The Threshold is used to control the connected discrete or continuous process; If the current value of source entity is larger than the threshold specified by the connector, the connector is enabled. If all input connectors of a process are enabled and the Activity property of the process is <i>true</i>, the process is enabled.</p> <p><i>Firing Rule</i> The Firing Rule is used to control the enabled/disabled state of a linked generic process; If the Firing Rule is set to <i>true</i>, the connector is enabled. As with discrete and continuous processes, a generic process is enabled if all of its input connectors are enabled and the Activity property of the process is set to <i>true</i>. The Firing Rule option can be a Boolean value or a script that returns a Boolean value.</p>
Log	Tells, whether to log the process values during simulation

8.2.1.4 Calculation Style

This section gives more details on the calculation style concept. The table below describes the impact of a firing process on the connected entities for different process types and calculation styles.

Calc Style	Process behavior

Speed	<p>When the process fires, the value of each input/output entity is decreased/increased by change value (delta). The formula for the change value (delta) depends on the kinetic style – see the table below.</p> <p>For the kinetic style <i>Custom</i> the absolute value of delta is the same for all input/output entities. For all other kinetic styles, the value of delta depends on connector specific parameters (e.g. <i>Connector Stoichiometry</i> or <i>Connector Custom</i>. Thus, the delta value may be different for different input/output entities.</p>
Add	<p>When the process fires, the value of each input/output entity is decreased/increased by change value (delta). The formula for the change value (delta) depends on the kinetic style – see the table below.</p> <p>For the kinetic style <i>Custom</i> the absolute value of delta is the same for all input/output entities. For all other kinetic styles, the value of delta depends on connector specific parameters (e.g. <i>Connector Stoichiometry</i> or <i>Connector Add</i>. Thus, the delta value may be different for different input/output entities.</p>
Update	<p>When the process fires, the value of each input/output entity is set to the update value. The script for the update value is specified in the <i>connector update</i> field. The update value may be different for different input/output entities.</p>

8.2.1.5 Kinetic Styles

This chapter gives more details on the kinetic style concept. The table below specifies the mathematical formula that is used to calculate the entity value change (delta) for all the various kinetic styles. Also, the parameters used for each kinetic style are listed in the table.

Kinetic style	Process type	Formula for the change value delta
Custom parameter: speed / add	continuous (speed calc style)	$\text{delta} = \text{speed} * \text{sampling interval}$
	discrete (add calc style)	$\text{delta} = \text{add}$

connector custom parameters: speed / add / update for each connector	continuous (speed calc style)	$\text{delta} = \text{connector_speed} * \text{sampling_interval}$
	discrete (add calc style)	$\text{delta} = \text{connector_add}$
Mass parameters: coefficient ₁ , coefficient ₂ , stoichiometry for each connector	continuous (speed calc style)	$\text{delta} = \text{m_product} * \text{coefficient}_1 * \text{coefficient}_2^{[\text{number_of_input_entities}] * \text{stoichiometry}} * \text{sampling_interval}$ where m_product is the product of all input entity values. For the input entity variables (m ₁ , m ₂ , ..., m _n) $\text{m_product} = m_1 * m_2 * \dots * m_n$
	discrete (add calc style)	$\text{delta} = \text{m_product} * \text{coefficient}_1 * \text{coefficient}_2^{[\text{number_of_input_entities}] * \text{stoichiometry}}$ where m_product is the product of all input entity values. For the input entity variables (m ₁ , m ₂ , ..., m _n) $\text{m_product} = m_1 * m_2 * \dots * m_n$
stochastic mass parameters: coefficient ₁ , coefficient ₂ , standard deviation and stoichiometry for each connector	continuous (speed calc style)	delta is randomly generated using the Gaussian distribution with the calculated delta_mean and specified standard deviation. delta_mean is calculated using the formula for the mass kinetic style: $\text{delta_mean} = \text{delta_mass} (\text{coefficient}_1, \text{coefficient}_2, \text{stoichiometry})$

	discrete (add calc style)	<p>delta is randomly generated using the Gaussian distribution with the calculated <code>delta_mean</code> and specified standard deviation</p> <p><code>delta_mean</code> is calculated using the formula for the mass kinetic style:</p> $\text{delta_mean} = \text{delta_mass} \cdot (\text{coefficient}_1 \cdot \text{coefficient}_2 \cdot \text{stoichiometry})$
connector rate parameters: rate and stoichiometry for each connector	continuous (speed calc style)	$\text{delta} = \text{rate} \cdot \text{stoichiometry} \cdot \text{sampling_interval}$
	discrete (add calc style)	$\text{delta} = \text{rate} \cdot \text{stoichiometry}$

8.2.2 Biological Properties

The biological properties are divided in predefined (or well-known) biological properties and user-defined or custom ones. Both, *custom and well known properties*, can be also displayed in *Biological Properties* frame.

The well-known properties depend on element type and CSO Class, e.g. a process will have different properties than an entity. An entity with *CSO Class Protein* will have many properties, while a *non-biological entity* (CSO Class) will have no biological properties. Therefore the number of rows displayed in the *Biological Properties* section changes with the change of element type or CSO Class.

Several Biological Properties can be set with values from a predefined CSO dictionary. In such a case the CSO Hierarchy tree control will be displayed.

8.2.3 Custom Biological Properties

The *Custom Biological Properties* allow the user to add his own properties. To add a new property:

- Double click the “...” in the *New Property* row
- Enter the name of the new property, e.g. A

This will display the new property A as a new row in the *Custom Biological Properties*. Now you can:

- Double click the “...” in the A row to set a new value for that property

8.2.4 Multiple Selection Sheet

This pane displays common properties of multiple objects selected in the active canvas. In this pane you may change a given property for all the selected objects at once in the following way:

- Select the elements to be modified on the canvas. You might select all elements.
- Go to the Element Setting frame and find the desired property in the property tree.
- Double click the cell and set the new value

Please note that the properties tree is normally in collapsed state and all properties are hidden. This is done to speed up the software, since the calculation of properties for multiple elements might be time consuming.

A concrete value is displayed in the property cell only if all selected cells have the same value of the property. Otherwise the cell is empty.

The *Multiple Selection* pane consists of 3 sections (categories) with such properties as:

- Shape section: Figure Type, Depth, Size, Fill Color, Line Color, Stroke
- **Biological Properties** and **Custom Biological Properties** sections as described above

8.2.5 Model and Canvas Property Sheet

This pane displays a number of properties describing the model in the active canvas and the canvas window itself. These properties cannot be edited

8.2.5.1 File Section

Property Name	Description
Name	Full path to the file
Modified	Date of the last file modification
Loaded	Date when the file was opened from filesystem

8.2.5.2 Model Section

Property Name	Description
Edited	Date when the model was last time edited
Total Count	Count of all elements in the model
Entity Count	Count of all entities in the model
Process Count	Count of all processes in the model
Connector Count	Count of all connectors in the model
Fact Vertex Count	Count of all fact vertexes in the model
Fact Edge Count	Count of all fact edges in the model
Group Count	Count of all groups in the model

8.2.5.3 Canvas Section

Property Name	Description
View Size	The size of the visible area
Actual Size	The actual size of the active model
Antialias Status	Toggles antialiasing on and off for the active canvas window
Grid Status	Toggles the grid display on and off for the active canvas

8.2.5.4 Biological Section

Property Name	Description
Organism	Defines the CSO property for the model
Cell Type	Defines the CSO property for the model
Tissue	Defines the CSO property for the model

8.3 Navigator

For a large model, the Navigator frame provides a convenient way to locate and display in the canvas window a desired part of the model. The Navigator displays a small view of the entire model, with a red rectangle marking the portion of the model currently shown in the active canvas. You can drag this rectangle around in order to navigate the model in the canvas window.

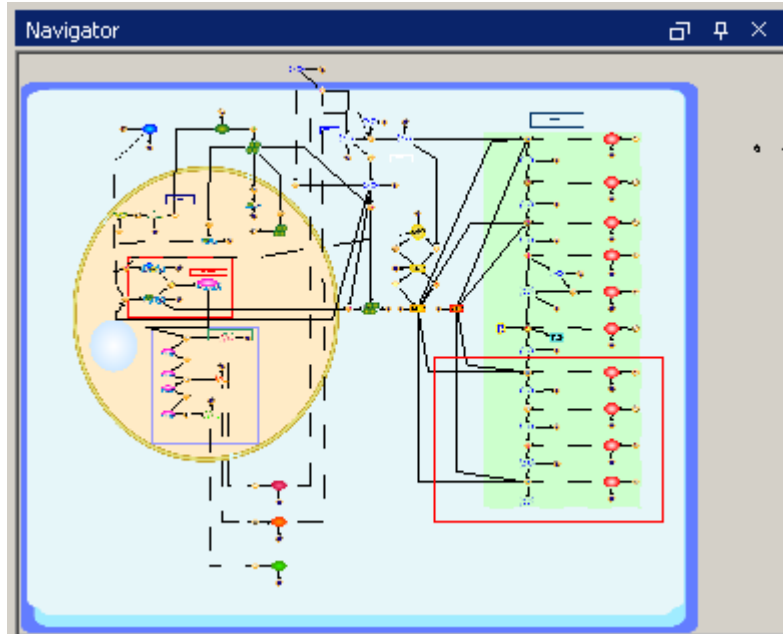

8.4 Simulation Settings

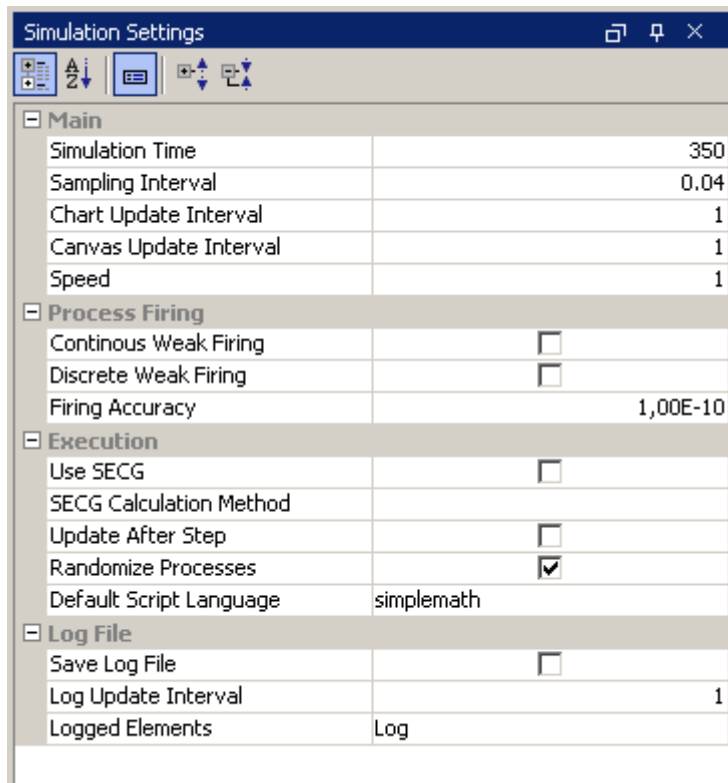

The *Simulation Settings* frame allows the setting of parameters that control the simulation execution for the model in the active canvas:

- *Sampling Interval* is the basic simulation input parameter that controls the simulation accuracy and performance. The smaller the *Sampling Interval*, the higher the accuracy.
- *Simulation Time* tells how long the simulation should last. The ratio *Simulation Time/Sampling Interval* defines the number of steps to be executed in the simulation.
- *Chart Update Interval* defines how often the **Chart Window** should be updated. This parameter has no impact on simulation results.
- *Canvas Update Interval* defines how often the canvas should be updated. This parameter is ignored if the simulation is executed in the fastest mode.
- All the times are specified in Petri net time units (pt).
- For a new model, all the settings are initialized on the base of user preferences – see the *Simulation Extra Options* in **Preferences** dialog box. The current settings are preserved in the model file.
- For the *Play* and *Fast Play* menu commands, the *Speed* option specifies how many times the simulation speed should increase over the speed in the regular *Play* mode. In reality, the maximum speed is limited by the hardware on which Cell Illustrator runs. Simulations started with the *Play* command with *Speed* value 1, 1pt should be executed in 1 second. *Fast Play* mode is always 10 times faster than *Play* mode – for *Speed* value 1, 10pt should be executed in 1 second. For simulations started with the *Fastest Play* command, *Speed* has no effect and the simulation is run with highest possible speed.
- *Continuous Weak Firing* enables/disables the weak firing option for continuous processes. By default, if this option off, a process cannot fire if there are not enough tokens in a connected input entity, i.e. if the calculated delta value is greater than the available entity value. Such behavior is in agreement with the Petri Net model, but is sometimes difficult to understand for normal biological reactions. If this option is on and weak firing is enabled, the process can fire even if the connected entity value is smaller than the delta calculated for the current step. In such a case the weak firing scale is calculated using the formula:

$$\circ \text{ scale} = \text{availableDeltaValue} / \text{calculatedDeltaValue}$$

After this the delta value for all input and output entities connected to the “weak firing” process are multiplied by the scale. The scale value is less than 1.

- *Discrete Weak Firing*. Enables/disables the weak firing option for discrete processes. By default this options is off.
- *Firing Accuracy*. The minimum change value for which a process fires. If the calculated delta value is less than the *firing accuracy*, the delta value is threated as zero and the process does not fire. This option is useful for the case of entity value converging to a given value in an asymptotic way.
- *Use SECG* determines whether to use the standard simulation engine or the simulation engine code generator (SECG). Both engines base on the same simulation model - *Hybrid Petri-net with extensions*. However the SECG

executes the simulation in a different way: first Java source code is generated for the model to be simulated; then it is executed as a usual Java program. The SECG engine is recommended for the following two cases:

- Simulation of large models; SECG will run large models much faster than the standard engine.
- Customization/integration of simulation model; The command Export | **Simulation Source Code** enables you to generate source code that can be customized by a programmer and/or reused in another software.
- *Update After Step* – defines whether the entity value should be updated after the step or after each process firing. In the later case the order of process firing in the same step will affect the simulation results.
- *Default Script Language* - defines the default script language for the model.
- *Save Log File* – If this option is true the values of selected elements will be logged
- *Log Update Time* defines how often the internal simulation log should be updated. The simulation log can be enabled by *Save Log File* option in this frame. This parameter has no impact on simulation results. The *Log Update Time* is ignored if the simulation is played in step mode.
- *Logged Elements* – defines which elements should be logged. It offers the following choices:
 - All Entities – Log all entity values, but do not log other elements (connectors and processes)
 - All without Firing – Log entity values and process/connector speed for all elements but do not log process state
 - All with Firing – Log everything: entity values, process/connector speed and process state for all elements
 - Chart – Log these elements which are displayed on charts – see Chart Settings frame. By default, no one element is added to the chart. In such a case, nothing will be logged during simulation and a CIL file will not be created during the simulation.
 - Log – Log these elements, which have the log option set to true. This option is displayed in Element Lists frame. By default, the Log option of all entities, processes and connectors is off. In such a case, nothing will be logged during simulation and a CIL file will not be created during the simulation.
 - Chart and Log – Log all these elements, which are displayed on chart or have the Log option set.

You need to set simulation parameters prior to starting simulation.

8.5 Chart Settings

The Chart Settings frame allows the visualizing of the simulation results with concentration or amount versus time graphs. You can:

- create a new chart,
- edit/customize an existing chart, and
- remove an existing chart.

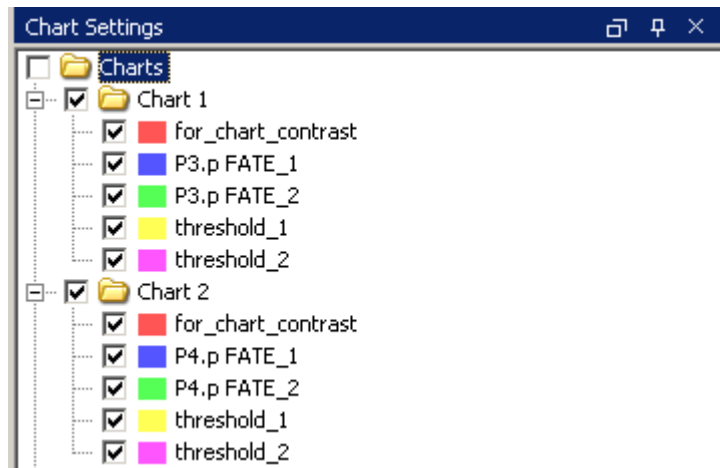

The *Chart Tree* displays all defined charts and their properties on two levels. The main level of the tree is the list of charts labeled by the chart names. The leaves of the tree are model elements that are included in the parent chart. A chart can display time series of the following simulation values:

- entity value
- process speed
- connector speed

One and the same element can be included in one or more charts.

The checkboxes allow for changing visibility of all charts, a single chart or a single data series. To hide all charts uncheck the tree root node – *Charts*.

You can add/define/remove charts or change its properties using context sensitive popup menu, which depends on selection item and includes the following commands:

- Create New Chart – creates new chart from entities and processes selected on active canvas. If nothing is selected chart will be empty
- Remove All charts – removes all charts defined in active document.
- Add Selection from Canvas – adds selected elements to the selected chart, if selection will be empty nothing happen. If more than one chart is selected, the entities are added only to the first one.
- Remove Selected – removes selected elements
- Rename – changes name of the chart
- Set Item Color – sets color of line on the chart. After add or create chart all items have random selected color. The User can also change color by double clicking Chart Item
- Show on Canvas – selects related entities or process on the canvas

- Centerize All Charts
- Centerize on Canvas – brings chart to the center of canvas

The entity, process and connectors names cannot be edited in the *Charts Tree*. The *Charts Tree* supports multiple selections including all possible combinations of chart and entity nodes - several charts and entities can be selected at once.

8.6 Simulation History

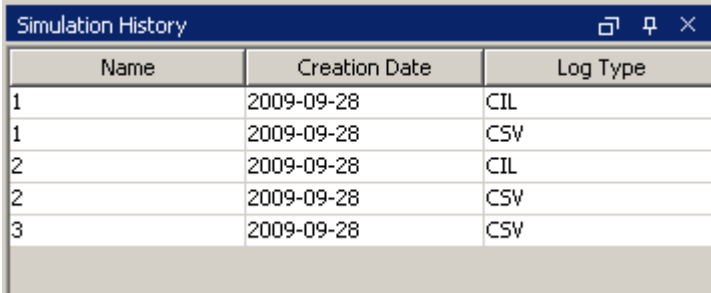

Name	Creation Date	Log Type
1	2009-09-28	CIL
1	2009-09-28	CSV
2	2009-09-28	CIL
2	2009-09-28	CSV
3	2009-09-28	CSV

In this frame, you can view and manage the simulation log files related to the model displayed in the active canvas. The simulation log file is either a comma separated value file (CSV) or a CSML file with log items (CIL) located in the simulation output folder of the model.

The simulation log file is created automatically after each simulation start if the *Save Log File* option was enabled in the **Simulation Settings** frame. Beside the CSV log file, the original CSML file that was used as input for this simulation log is stored in the log output folder .

The *Simulation History* frame consists of the main table that contains a list of the log files and a context menu with the following commands: Rerun, Open Log, Open Backup CSML File, Open Directory, Export CIL/CSV File.

Each row in the *Simulation History* table represents one log file (CSV or CIL) and contains the following properties displayed in columns:

- Name – the filename
- Creation Date - date and time of the simulation
- Type – CSV or CIL

The CI logs are presented in the alphabetical order of their file names. The list supports multiple selections: zero, one or more items can be selected in the list to mark the scope of Rerun command.

The button *Rerun* opens the selected logs (one or more) in the main window of *CI Player* application. The main window of *CI Player* application becomes the active application and the selected simulation log is ready for a replay.

The command *Open* opens the selected log file in the default CSV file viewer/editor.

The command *Open Directory* opens the simulation output directory that contains all the log files.

The command *Export CIL File* allows you to create and save a special CI log file (CIL) which can be viewed and analyzed in *Cell Illustrator Player*. A CI log is an XML file that consists of two parts: the input model and a time series of values for the logged properties. Since CIL stores the model in the same format as in the original project file, you can open a log file with Cell Illustrator and edit the model. However, saving the edited model into the original log file will erase the time series and any other simulation history information. Therefore, you should use the Save As command of Cell Illustrator if you would like to recover the model from a log file for further editing.

8.7 Biological Elements

- While you can use the menu options and toolbar buttons to add elements, biological pathways can be created faster and more intuitively by dragging and dropping appropriate elements from the Biological Elements frame.

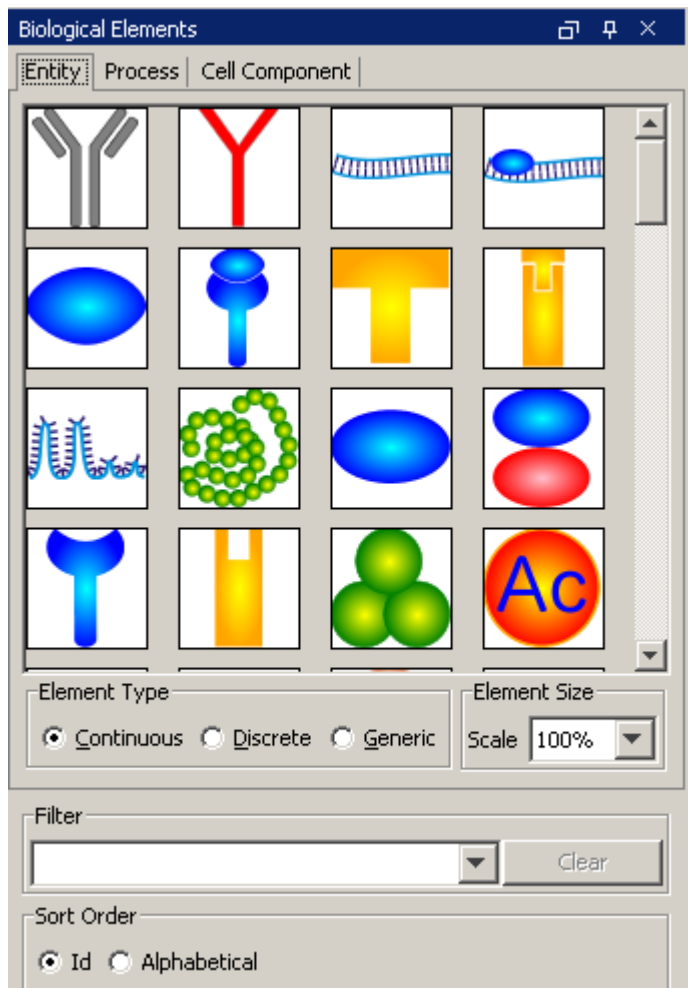

You can use this frame to:

- find a picture that represents a given biological entity, process or cell component
- add a new element to the canvas
- replace the image of an existing elements

To find a picture that represents a given biological entity, process or cell component:

- Go to the desired tab: *Entity, Process or Cell Component*.
- Enter one or more characters into the filter box
- The possible choices that contain the entered characters are displayed in the drop down list. Also the list of pictures is filtered, so that only the possible choices are displayed, while all other pictures are hidden
- Select the desired element from the drop down list. The corresponding picture is displayed.

To insert a biological element, proceed as follows:

- Select a picture in the *Element*, *Process* or *Cell Component* tab. The picture description and size will be displayed in a fly-over help string when you position the mouse cursor over the picture.
- Select the *Element/Process Type*
- Select the *Element Size* by defining the picture scale.
- Click on the chosen picture, drag it to the active canvas and drop it there by releasing the mouse button.

Pictures from the *Entity* or *Process* tabs are inserted as elements of the specified type: *Continuous*, *Discrete* or *Generic*. Pictures from the *Cell Component* tab are inserted as images and they do not have any impact on the simulation results.

To replace the image of an existing element, proceed as follows:

- Select a picture in the *Element* or *Process* tab. The picture description and size will be displayed in a fly-over help string when you position the mouse cursor over the picture.
- Click on the chosen picture, drag it to the active canvas and drop it over the existing entity or process by releasing the mouse button.

Please note that pictures from the *Entity* can be used to replace entity elements only, while pictures from *Process* tab can replace process elements only. The replace function is not available for pictures from the *Cell Component* tab.

8.8 Graph Layout

Using this frame, you can “beautify” the graph layout of the model in the active canvas. This option can be especially useful when importing models from the BioPACS database or converting models from other formats (Edge files, CellML, SBML)

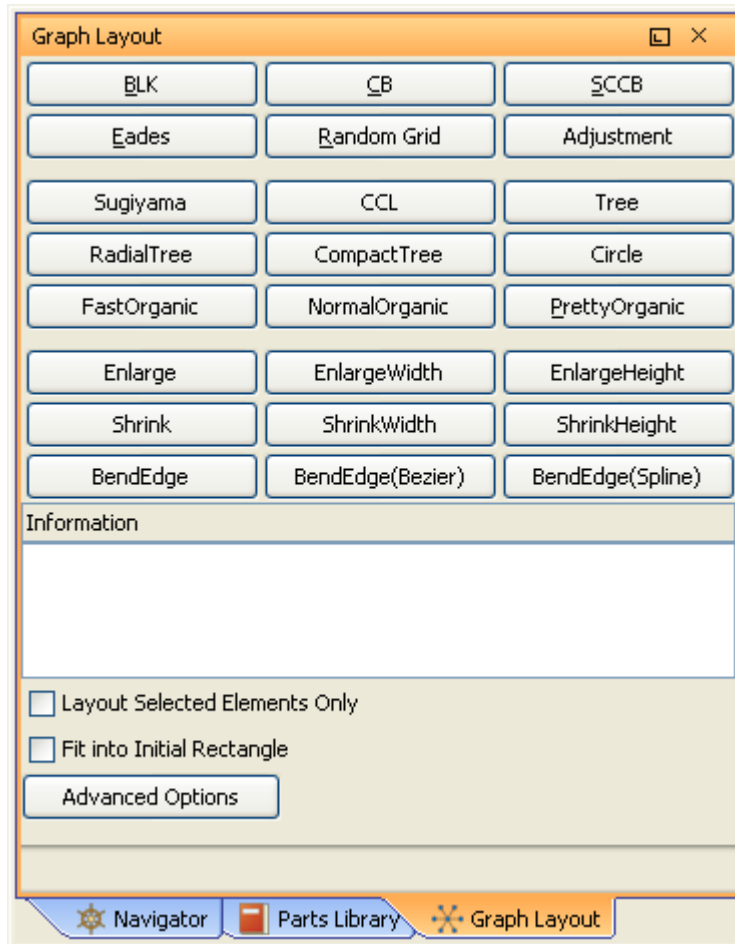

- Each of the algorithm buttons *BLK*, *CB*, *SCCB*, *Eades*, *Random Grid*, *Adjustment*, *Sugiyama*, *CCL*, *Tree*, *Radial Tree*, *Compact Tree*, *Circle*, etc. start the layout algorithm for the graph that is displayed on the active canvas
- The *Enlarge* and *Shrink* buttons allow for linear scaling of the graph in the horizontal, vertical or both directions.
- *Layout Selected Elements Only* allows to limit the layout to the canvas selection.
- *Fit Into Original Rectangle* allows to keep the graph size unchanged after the layout operation.
- *Advanced Option* button – opens the *Graph Layout Options* dialog .

8.9 Gene Mining

This frame displays the detailed information concerning the selected genes retrieved from the PubMed, KEGG and MIM databases. You can extract this information either for a selected subset of genes or for all the genes in the network.

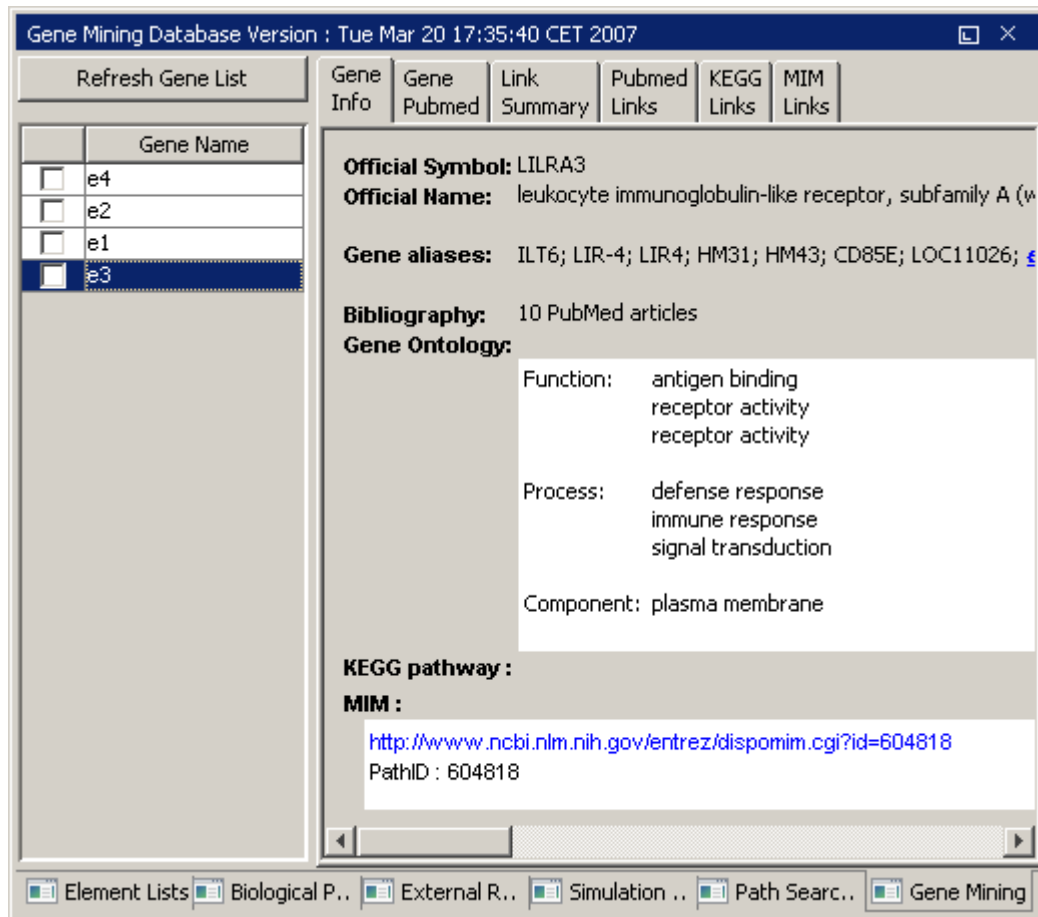

The set of genes upon which gene mining is performed depends on the canvas selection at the time of the execution of the **Analyze | Gene Mining** command in the following way:

- a. if selection is not empty then gene mining is performed upon the set of selected genes
- b. otherwise, if none of genes in the network is selected, the gene mining is performed on all genes in the network.

The Gene Mining frame uses an internal database which is periodically updated. You may download the newest version of this DB by executing **Analyze | Download Gene Mining Database**.

8.9.1 Gene List

Gene Mining searches for articles concerning selected genes and for links between these genes. The set of genes that has been analyzed in Gene Mining is displayed in the Gene List panel. Selecting a gene in this list, displays the information about this gene in the following described six panels:

8.9.2 Gene Info

Displays the main information about the gene selected in the Gene List: gene name, official name, aliases and number of PubMed articles, gene ontology, information about gene functions, processes and components

If information about an MIM or KEGG Pathway is present for the selected gene, you may click on the hyperlink to open it in the web browser.

A gene can be represented by its official symbol or an alternate symbol (alias) on the canvas. The symbol used on the canvas is highlighted in blue and underlined in the Gene Info panel. Clicking on it opens detailed information about this gene symbol from Entrez Pubmed database in the web browser.

This information is especially useful when the gene alias is used on the canvas. In such cases you can check in the Entrez Pubmed database, whether the gene alias is unique or ambiguous. If it is ambiguous, the Entrez Pubmed database displays you all possible official symbols for this gene alias.

8.9.3 Gene Pubmed

In this panel you can observe the Pubmed article list concerning the selected gene. Each article includes the following details: authors, title, journal and publication date. You may also display the article abstracts by selecting the checkbox of each article.

8.9.4 Link Summary

For a selected gene, this tab lists all related genes in the analyzed set as well as the number of PubMed, KEGG and MIM identifiers that the gene has in common with other genes in the analyzed set.

8.9.5 PubMed Links

For a selected gene, this tab lists Entrez PubMed entries that link this gene to one or more genes in the analyzed set. You can expand each entry to see the full abstract. The list of related genes is displayed next to each link.

8.9.6 KEGG Link

For a selected gene, this tab lists KEGG pathways that link this gene to one or more genes in the analyzed set. The list of related genes is displayed next to each link. Click on the http link to access the WWW site with information on a particular MIM identifier.

8.9.7 MIM Links Panel

For a selected gene, this tab lists MIM identifiers that link this gene to one or more genes in the analyzed set. The list of related genes is displayed next to each link. Click on the http link to access the WWW site with information on a particular MIM identifier.

Note: You may use the shortcut keys Tab and SHIFT+Tab to navigate between the panels. The Tab key switches you one panel forward (to the right), while SHIFT+Tab one panel backward (to the left).

8.9.8 Refresh Button

This button starts the gene mining process for the selected subnet on the active canvas. It has the same meaning as the [Analyze | Gene Mining](#) command.

8.10 External References

In this frame you can view/manage references of the selected elements in the active canvas. You can edit single table cell by double clicking on it or open the context menu by right clicking on it.

- *External References* is a frame that displays the list of references associated with the currently selected elements.
- The references are shown in two tabbed tables: *Publications* and *Database References*.
- The reference table displays the reference details in four columns: Database, Reference Name, Comment and URL. You can edit any of those reference details by double clicking on the desired table cell.
- If more than one element is selected, the references are grouped by their parent element (entity, process, connector, etc..)
- For database and publication references, the name and URL is generated automatically when the reference is defined. In some cases you might want to change the default name or URL, e.g. by adding a special, non-default parameter to the URL. Therefore editing of cells in the table is useful for the refinement of automatically generated URL and name attributes.
- Depending on the reference type, the comment property can be used for various purposes. E.g. for it can be the term that is defined by a vocabulary reference, or it can be a description of the relationship between the element and the reference.

8.11 Comments

In this frame you can view/manage comments of the selected element in the active canvas. You can edit single table cell by double clicking on it or open the context menu by right clicking on it.

- *Comments* is a frame that displays the list of comments associated with the currently selected element.
- The table displays the comments details in two columns: Type and Comment. You can edit any of those reference details by double clicking on the desired table cell.

8.12 Project Manager

CI Project Manager is a user interface to pathway models stored on *CI Online Server*. To access the remote *CI Online Server*, the user must be logged in.

CI Project Manager allows the user to store, organize and share CSML models (e.g. pathways) and other data on a remote server. Additionally you can access public and proprietary pathway libraries using the Libraries section. *Project Manager* Frame consists of menu containing *Project*, *File*, *Sort* and *Search* groups, simple search panel, and graphical file browser.

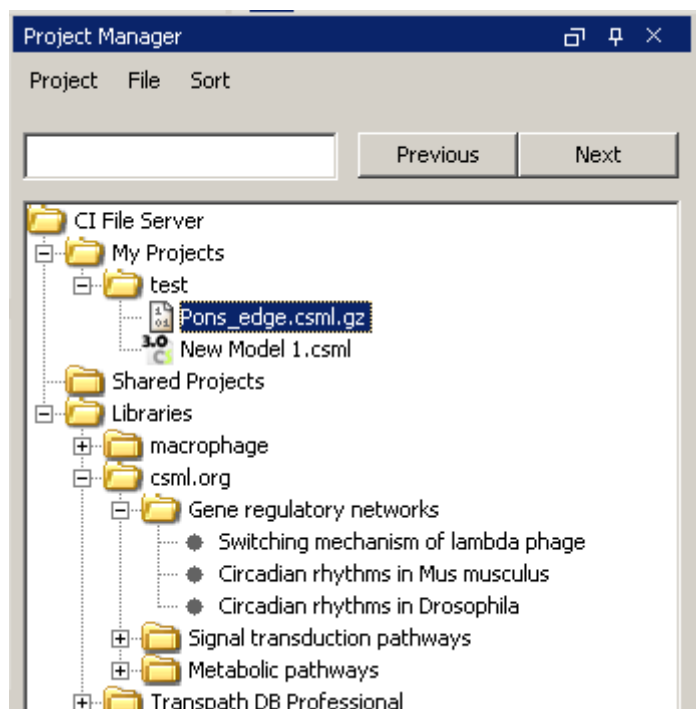

To find a pathway in project tree:

- Enter the search string, one or more characters, into the edit box
- Press the *Next/Previous* button to select the next/previous item that matches the search string.
- Browse through the search results or narrow the search by applying additional criteria.

To insert a biological element, proceed as follows:

- Select the desired element(s) in the project tree
- Click on the chosen tree item, drag it to the active canvas and drop it there by releasing the mouse button. You may also release the mouse over an empty space in the CI workspace; this will create a new canvas and drop the selected model there.
- Alternatively, choose the *Open* or *Insert into Active Canvas* from the File or context menu.

8.12.1 File Browser – Project Manager Tree

File browser contains 3 sections: My Projects, Shared Projects and Libraries.

- My Projects

My Projects folder contains user's projects. User has full privileges to projects stored in this folder. To create new project user has to right-click *My Projects* and select *New Project* from the context menu.

Projects are displayed as yellow folder icons (as “testProject” in figure above). If you share project with other users – its icon is red (as for “project1” in figure above).

- Shared Projects

Shared Projects folder contains projects that other users share with you. Depending on your privileges, you can read and/or write to these projects. You cannot delete shared project.

Note: The project owner can delete any of his projects. In such case, you will lose all information that you have created in shared project.

- Libraries

Libraries folder contains files that can be imported into your models. You cannot in any way modify contents of this folder.

Note: Access to some libraries (such as Transpath) requires a special license-CI Online module.

8.12.2 Menu

The *top menu* and the *context menu* contain actions that can be performed in the Project Manager frame. Options are active only in proper context. Additionally, all actually available options can be found in context menu that opens after right-click on item *Project Manager Tree*.

- Project menu

Project menu contains options applicable to projects. It is active only for My Projects folder.

- **Upload**

This allows you to upload local model to the server.

- **Upload from canvas**

This allows you to upload model from active canvas to the server.

- **Remove**

This command allows you to remove project from server.

- **Share this project**

This command allows you to share project with other users. Selecting this option opens dialog, when you can add or remove users that you share project with. When there is at least one user in share list, project icon turns red.

- **Rename**

This command allows you to rename project.

- **Information**

This command shows Project Information dialog:

- **File menu**

This menu is active only when file is selected in file browser. Some actions may be inactive in Libraries and Shared projects folders.

- **Open**

Opens file into new canvas.

- **Save as**

This option allows user to save file from Project Manager to local disk.

- **Information**

Displays File Information dialog

- **Insert into active canvas**

This option imports selected file into active canvas

- **Remove**

This option allows user to remove file from Project Manager. User can remove files only from “My Project” folder.

- **Rename**

This option allows user to rename file. User can rename files from “My Projects” folder only.

- **Sort**

In this menu you can set files order: by name or by creation date

8.12.3 Simple Search Panel

Simple Search panel allows the user to find files containing given string. To find an item in the *Project Manager* tree: specify the filename to be search for (or part of it), press the *Previous* or *Next* to select the next/previous search results.

8.13 CSMLDB Search

The *CSMLDB Search* frame is an interface that allows for submitting queries to the remote CSMLDB database. To access the remote CSMLDB database, the user must be logged in to the CI Online server.

Using this frame you can search in the CSMLDB database for molecules (entities) and for reactions (processes) and import them into active canvas.

To find a biological entity or process in CSMLDB:

- Go to the desired tab: *Entity*, *Process*.
- Enter the search string, one or more characters, into the *Search For* edit box
- Choose the search options filtering, sorting results
- Press the *Find* button. And wait until the search results are displayed in the table. During this the *Find* button changes to *Cancel*
- Narrow the search by applying additional criteria or
- Browse through the search results. You may sort and/or filter the results by clicking the column header.

To insert a biological element, proceed as follows:

- Select the desired element(s) in the results table.
- Check the option *Merge*, if you want to merge entities with the same *TranspathDB ID*. Otherwise uncheck this option
- Click on the chosen row(s), drag it to the active canvas and drop it there by releasing the mouse button. You may also release the mouse over an empty

space in the CI workspace; this will create a new canvas and drop the selected elements there.

- Alternatively, press the *Import* button to add the active elements to the active or a new canvas.

8.13.1 Molecule Search – Entity Tab

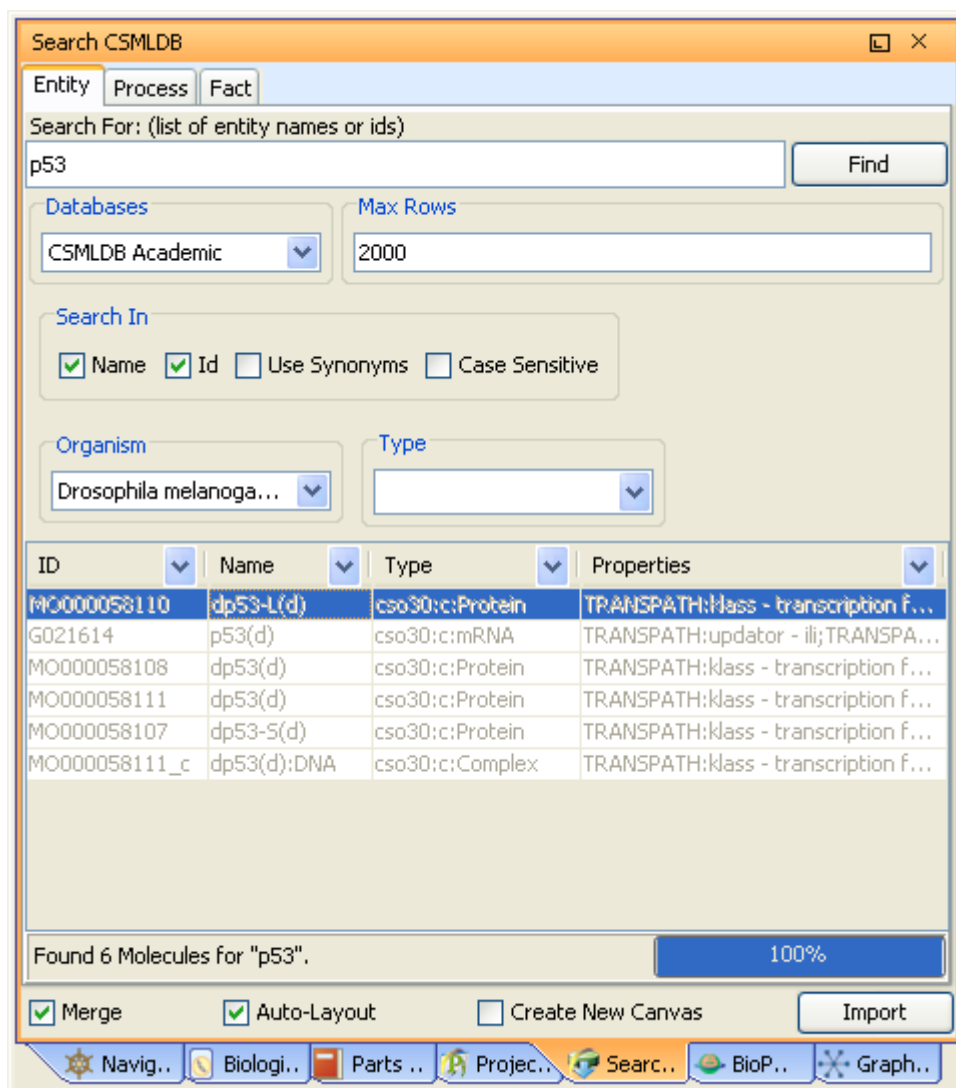

Molecule (Entity) search is performed by the execution of the following steps:

- Enter a search strings into the *Search For* edit box. You may enter several strings separated by semicolon.
- Select the properties to be searched for using the check boxes in the *Search In* panel.
- Choose the organism and entity type to be searched for,

- Press *Find* button

Search may take up to several seconds. You can cancel the search and make another query, but you are restricted to maximum of 4 running queries at one time. If 4 queries are still running on server, message box will appear when trying to run next search.

The *Molecule Search* panel consists of the following controls:

- **Search For**

In this field, you can specify part of the name or id of entity. The CSMLDB database will be searched for all entities that contain given name in their id and/or name depending on the settings in *Search In* box.

You may specify several search strings separated by semicolon (;). In this case the results will be the sum of each single string search. It means all entities will be matched that include at least one of the specified strings.

If this field is empty, CSMLDB will search for any entity satisfying other criteria.

- **Search In**

In this field you specify, which entity property name, id, or both should be matched during the search.

If none of options is selected search will not be performed.

- **Organism**

In this combo box you can select the desired organism. This will limit the search to reactions and pathways for organism of the selected type.

If this field is empty Organism will not be used as a search criterion.

- **Type**

In this combo box you can select the desired entity type. This will limit the search result to the entities of the selected type. The type is equivalent to Entity CSO Class.

If this field is empty entity type will not be used as a search criterion.

- **Max Rows**

In this field you can specify the maximum number of rows to be displayed on a single page. Default value is 2000.

8.13.2 Reaction Search – Process Tab

In this panel, you can search for all processes that contain an entity with given name/id.

Search CSMLDB

Entity Process Fact

Search For: (list of entity names or ids)

p450 Find

Databases: CSMLDB Academic Max Rows: 2000

Search In: Name Id Use Synonyms Case Sensitive

Relation: Input Output

Organism: Bos taurus Type: [Empty]

ID	Name	Reaction	Type	Properties
XN000103616_0	CYP11A1(b) -->...	cso30:c:Proces...	ME_Translation	TRANSPATH:re...
XN000103619_0_r	Adx(m.s.) + P4...	cso30:c:Proces...	ME_Dissociation	TRANSPATH:re...
XN000103619_0	Adx(m.s.) + P4...	cso30:c:Proces...	ME_Binding	TRANSPATH:re...
XN000103615_0	CYP11A1(b) -->...	cso30:c:Proces...	ME_Translation	TRANSPATH:re...

Found 4 Processes for "p450". 100%

Merge Auto-Layout Create New Canvas Import

Navig.. Biologi.. Parts.. Projec.. Searc.. BioP.. Graph..

Reaction Search is performed by the execution of the following steps:

- Enter a search string into the *Search For* edit box. You may enter several strings separated by semicolon.

Note: Do not enter process names or IDs, but entity names or IDs. The program will search for **entities** that match the *Search For* text and then find all reactions with those entities. Therefore the entered string should be an entity name or a part of it.

- Select the properties to be searched for using the check boxes in the *Search In* panel.
- Choose relation type between entity and process: input or output,
- Choose the organism and process type to be searched for,

- Press *Find* button

Search may take up to several seconds. If you want, you can cancel search and make another query, but you are restricted to maximum of 4 running queries at one time. If 4 queries are still running on server, message box will appear when trying to run next search.

The *Reaction Search* panel consists of the following controls:

- **Search For**

In this field you can specify part of the name or id of entity. The CSMLDB database will be searched for all processes that are connected with an entity containing given name in their id and/or name (depending on the settings in *Search In* box).

You may specify several search strings separated by semicolon (;). In this case the results will be the sum of each single string search. It means all entities will be matched that include at least one of the specified strings.

If this field is empty CSMLDB will search for any processes satisfying other criteria.

- **Search In**

In this field you specify, which entity property name, id, or both should be matched during the search.

If none of options is selected search will not be performed.

- **Relation**

In this field, you can limit the search to input or output entities only. If none of options is selected, search will not be performed. If both are selected, the search results will include entities connected to the process by input as well as output connectors.

- **Organism**

In this combo box you can select the desired organism. This will limit the search to reactions and pathways for organism of the selected type.

If this field is empty Organism will not be used as a search criterion.

- **Type**

In this combo box you can select the desired process type. This will limit the search result to the processes of the selected type. The type are equivalent to CSO Molecular Events Types.

If this field is empty, process type will not be used as a search criterion.

- **Max rows**

In this field you can specify maximum rows number to be displayed at single page. Default value is 2000.

8.13.3 Import Button

You can import some or all search results into the active CI canvas, or into new canvas.

To do this, you have to select one or more search results in Search Results Table, and press *Import* button.

For Molecule Search, all selected entities with their external references will be imported.

For Reaction Search, all selected processes with all connectors and entities associated with them, as well as all their external references will be imported.

8.13.4 Import Options

The Import options consist of three checkboxes: *Merge*, *Auto-Layout* and *Create new canvas*.

If option *Create new canvas* is selected, object will be opened in new canvas. Otherwise it will be added to the active canvas.

If option *Merge* is selected, new object will be merged with the elements existing in the active canvas.

If both options *Create new canvas* and *Merge* are selected, new object will be merged with the elements from active canvas and all object will be opened in new canvas.

If option *Auto-Layout* is selected, a special layout is applied to the imported elements.

When importing elements by *Drag and Drop* the option *Create New Canvas* is ignored.

8.13.5 User Defined CSMLDB

You might create your own CSMLDB from a set of CSML files.

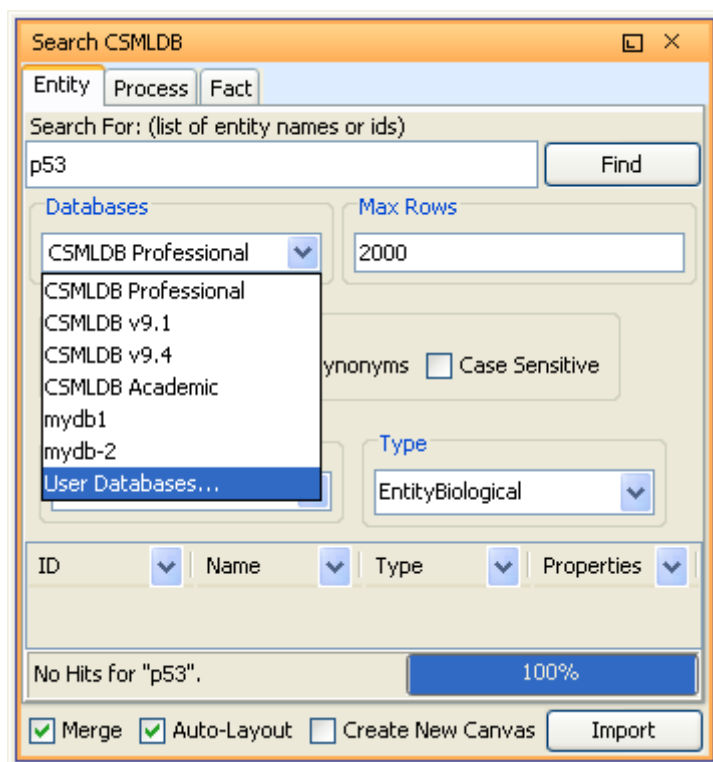

The *User Databases...* item in *Databases* combo-box opens the **Manage User Databases** dialog box, where you can create/remove and control the user defined CSMLDB databases. All databases created and listed in the *Manage User Databases* dialog box are listed in the *Databases* combo box and can be searched in the *CSMLDB Search* frame.

8.14 Parts Library

With *Part Library*, you can organize a repository of frequently used model parts in a tree. Then, you can assemble more complex models out of lower-level “parts” stored in the repository. Cell Illustrator comes with several pre-registered parts to demonstrate this function. Models in the repository are organized into a tree of components. Each model is stored as a separate file in the user’s home folder; the component tree is stored in the *parts.xml* file.

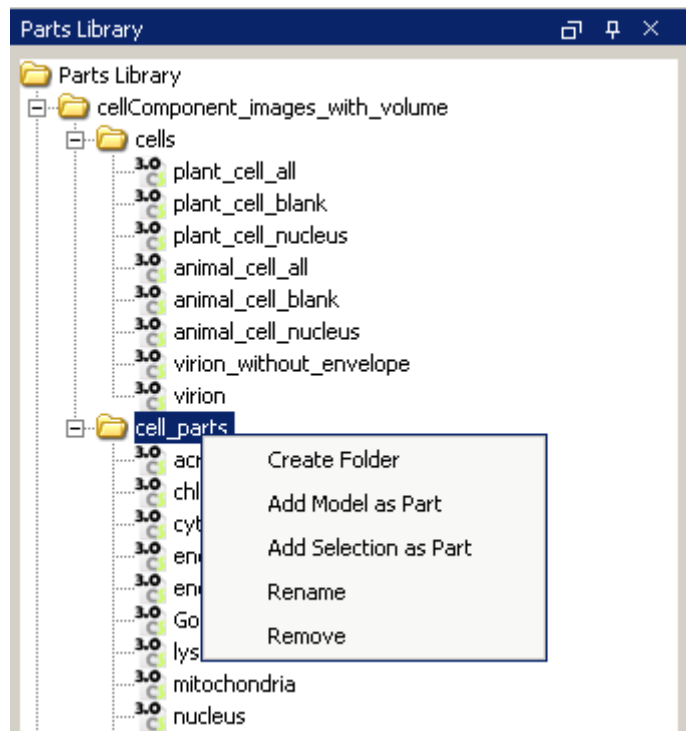

Within the *Edit Parts* frame, you can:

- *Insert* a model part into the active canvas by clicking on its name
- *Open* a model from the library in a new window.
- Add a new part to the repository using *Add Model as Part* or *Add Selection as Part* commands
- Manage and organize the parts in the repository by clicking the *Create Folder*, *Remove*, *Rename* menu item.

All the above commands are available in the popup menu that is displayed after clicking a tree element with the right mouse button.

To insert/open a part to the active canvas:

- Select the desired part to be inserted in the tree
- Right-click on selected item and choose *Insert/Open* in the popup menu
- Alternatively, click on the chosen tree item, drag it to the active canvas and drop it there by releasing the mouse button.

8.15 BioPACS Library

- Imports a metabolic pathway map from the BIOPACS-KEGG Web site, which contains KEGG models mapped/converted to CSML files.
- In this window, you can browse through the tree of models, select one of them, choose import options and open in a new canvas window.

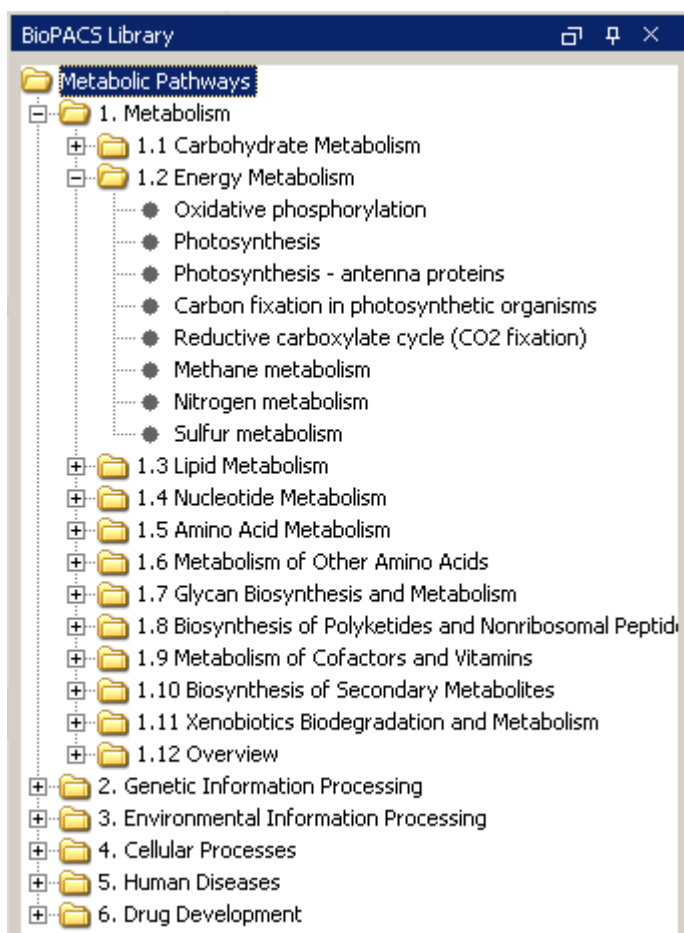

- If the *Add Inhibitor* is turned on, all inhibitors of chemical reactions influencing the imported model that are present in the BioPACS are added.
- If the *Add Effector* is turned on, all effector molecules of chemical reactions influencing the imported model, present in the BioPACS, are added
- If the *Add Cofactor* is turned on, all cofactors of chemical reactions influencing the imported model, present in the BioPACS, are added

The *View Web Site* button opens the BIOPACS converter site in your default browser. The *Open* button starts a download of the selected model and opens it in the workspace.

8.16 View Settings

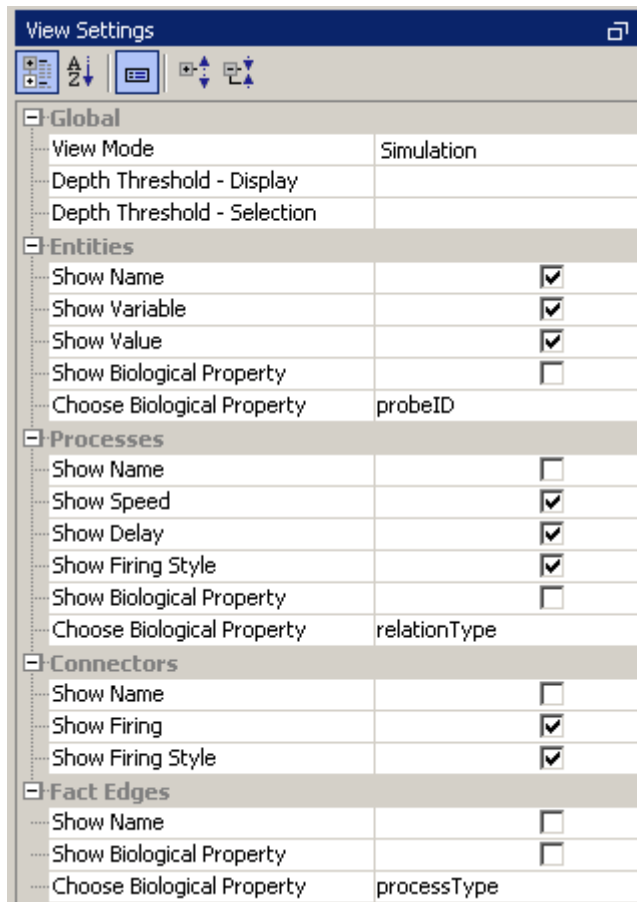

This frame allows you to set global visualization settings for the Cell Illustrator. The view settings are stored as user preferences and apply also the next time you start the application. A change in the settings results in an immediate update of all canvas windows.

- **View Mode**

This option allows you to change the visibility of several label types by one click. In the list of available choices, the user can select:

- *All* – all label types visible
- *Edit, Simulation, View* – display label types which are important for the selected scope
- *None* – all label types are hidden
- *Custom* – user defined label visibility

- **Depth Threshold - Display**

This option allows you to set depth threshold of active canvas. Every item on canvas has *Depth* parameter. Global *Depth Threshold Display* setting sets depth that elements can be displayed to. E.g. if entity has depth of 60, and global *Depth Threshold -Display* is set to 50, entity can't be displayed. To be visible, item must have *Depth* smaller than actual *Depth Threshold* value

- **Depth Threshold - Selection**
This option allows you to set depth threshold of active canvas. Every item on canvas has *Depth* parameter. Global *Depth Threshold* setting sets depth that elements can be selected to. E.g. if entity has depth of 60, and global *Depth Threshold* is set to 50, entity can't be selected (but is still visible on canvas). To be active, item must have *Depth* smaller than actual *Depth Threshold* value.
- **Show Label Type**
This flag tells whether the selected label type can be displayed. If the flag is *off*, then the selected label type is always hidden.
- **Choose Biological Property**
In this entry the user can select the biological property that should be displayed on the canvas.
- **Save As Custom**
This command saves the current label visibility settings to *Custom* view mode.

8.17 Biological Properties

For the model in the active canvas, this frame displays elements together with their biological properties in a tabular view.

Biological Properties					
Entity	Process	Connector	Fact Edge	Fact Vertex	Group
Id	Name	Cell Component	Biological Event	Synonym	
p345	p2	plasma membrane (integral to plasma membrane)	dimerization		
p78	p70	extracellular	unknown degradation		
p363	p29	extracellular	translation		
p335	p160	cytosol	unknown degradation		
p353	p353	extracellular	translocation		
p270	p22	plasma membrane (integral to plasma membrane)	binding		
p99	p48	cytosol	translation		
p253	p53	cytosol	unknown degradation		

The *Biological Properties* frame consists of the tabbed tables *Entity*, *Process*, *Connector*, *Fact Edge*, *Fact Vertex* and *Group*.

The following operations can be done for each of the table:

- Select an element on the canvas by clicking on a row
- Sort rows according to the specified column by clicking on the column header,
- Filter rows by specified column by clicking on combo box on header of the column,
- Edit a given property by double clicking a cell

- Customize the visible column by right click on column header and choosing one of the menu items:
 - o Hide column
 - o Show All Hidden Columns
 - o Select Visible Columns
 - o Restore Default Columns

8.18 Simulation Errors

This frame displays the errors that occurred during script execution in the most recent simulation.

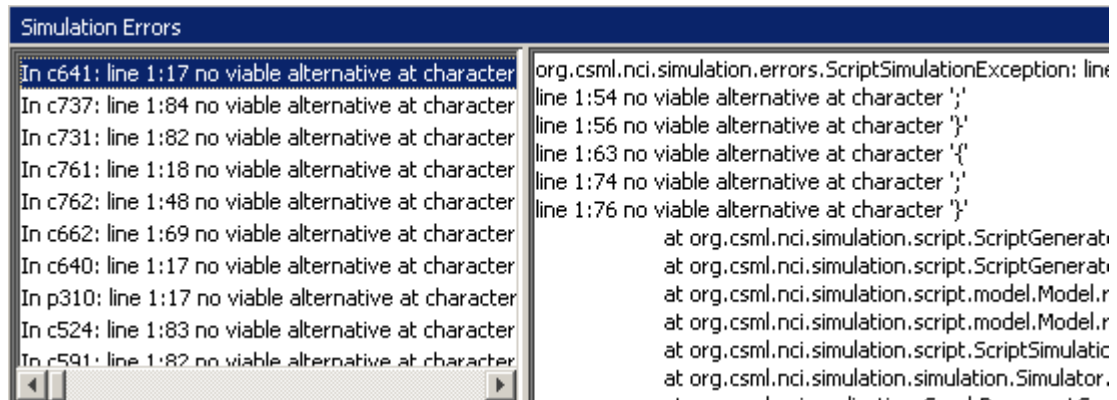

The frame consists of two panes: the left panes with the list of all errors and the right pane with the details of the selected error.

Each row in the left pane represents one script execution error. Each error is described by the element name, the error location - number of line and position in the script and the short error message. Selecting a row in the left pane, selects the corresponding element on the canvas and displays the error details in the right pane.

Many script execution errors will occur due of invalid script language selection. A valid script in *Java* language might be invalid if the script is executed in another language, e.g. *simple-math*, *Pnuts*, or *JS*. Therefore, if you get many errors, please make sure that the default script language for the model and the individual script language for the selected elements are correct.

8.19 Path Search Results

This frame displays the list of paths that have been discovered during the [Path Search](#).

Path Search Result									
	0		1		2		3		4
1	e1	→	p1						
2	e1	→	p1		→ e64				
2	e1	→	p1		← e67				
3	e1	→	p1		→ e64		→ p2		
3	e1	→	p1		← e67		← p4		
4	e1	→	p1		→ e64		→ p2		→ e65

Each path is displayed in one row and described by the following properties:

- column 1: path length – the number of connectors in the path
- column 2: the first entity in the path – the entity specified in the Search

From field

- column 3: connector direction – the direction of the connector between the first entity (column 2) and the connected process (column 4)
- column 4: the first process in the path
- column 5: connector direction – the direction of the connector between the first process (column 4) and the second entity (column 6)
- column 6: the second entity in the path
- etc.

Click a row in the table to select the corresponding path on the canvas. CTRL+click (Apple+click on Mac) and SHIFT+click allow for the addition or removal of multiple items to the selection.

8.20 Expression Plot

The expression plot displays more detailed information about the results of the micro array experiments, which have been executed to obtain a gene network.

Note: To create and view the standard expression plot an additional expression file is required. This file contains additional experimental data that is not included in CSML model file. Each entity must have defined the *probeID* biological property to match the value in expression file. To view the partial residual plot, *bspline* data stored in edge comments (in CSML file) is required.

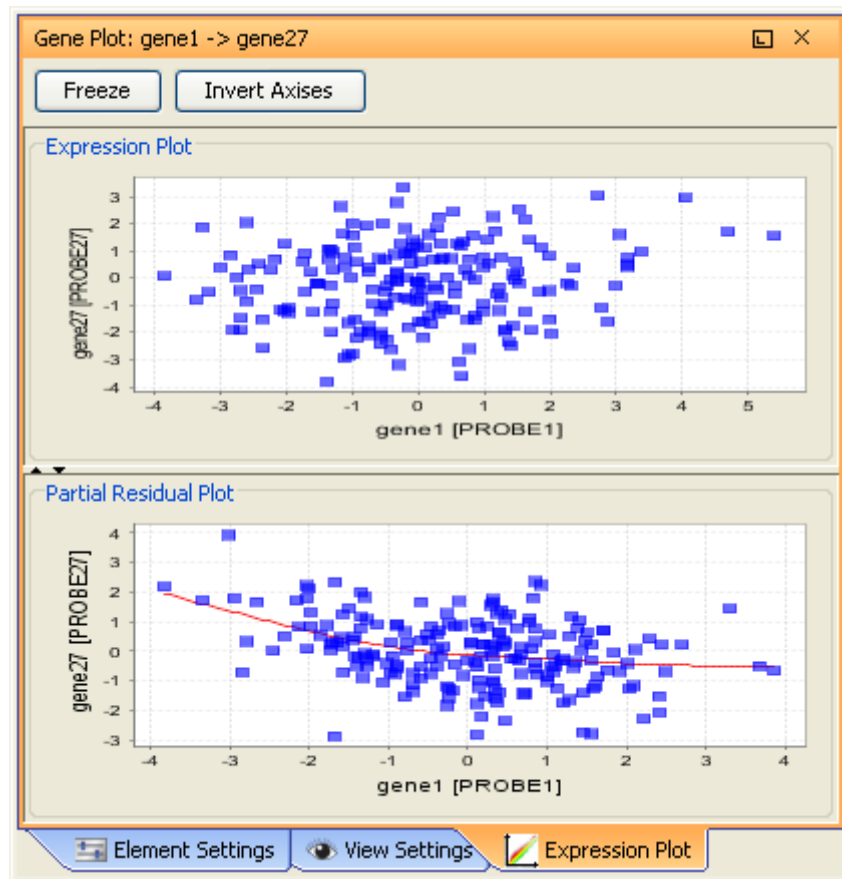

The *Expression Plot* frame is displayed for the selected pair of entities or for the selected edge. The selected entities are displayed on the X and Y axis.

Note: The expression plot will be displayed only if the canvas selection contains exactly two entities or exactly one edge. Otherwise the expression plot cannot be displayed.

To view the expression plot:

- Make sure that the expression file is available. For this, open the Preferences dialog box and check that the *Expression File* location is correctly defined in the *Expression Plot* section
- Select exactly two entities or exactly one edge on the canvas.
- Choose Analyze | Expression Plot from the menu or the Expression Plot icon from the right side toolbar
- Press the Freeze button to keep the selected expression plot
- Select a pair of entities (or another edge) to view its expression plot.

9 Dialog Boxes

9.1 CI Online Login Dialog

This dialog box is displayed when the authentication on the CI Online sever is required. After a successful login the user data is displayed in the CI title bar in the form user@server e.g. demo@cionline.hgc.jp. Depending on your account status, you might access remote data and services available on the CI Online server, such as: [Project Manager Dialog](#), [CSMLDB Search Dialog](#).

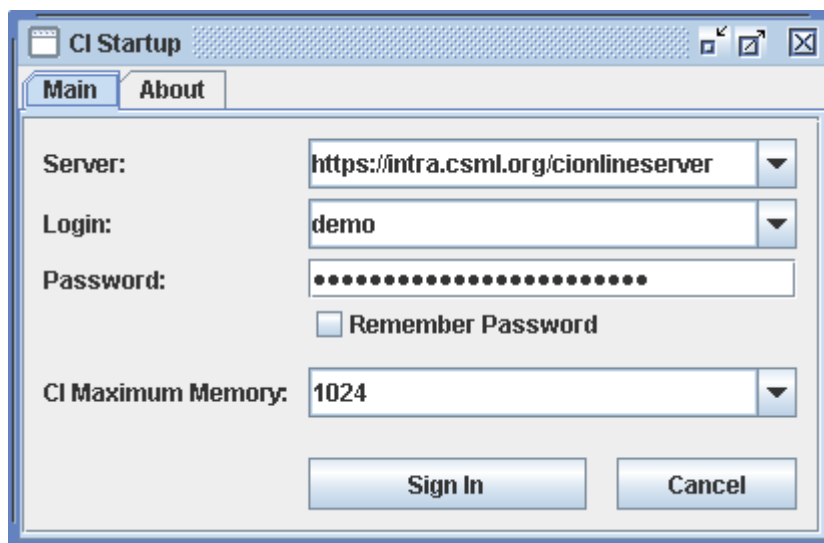

Before you login the CI Online Server, you need to register and obtain the account name and password. Then you enter this data in the Login dialog box:

- *Server* – the address of CI Online Server
- *Login* and *Password* – your login data

The other options in the Login dialog are:

- *Remember Password* – select this option to store your login data on the local computer. This will speed up the login when the dialog will be displayed the next time.
- *CI Maximum Memory* – defines the maximum memory for the CI process. The default, recommended value is 1024 MB. Enlarge this value for large models; or shrink the “heap size”, if there is not enough RAM on your local PC.

9.2 Preferences

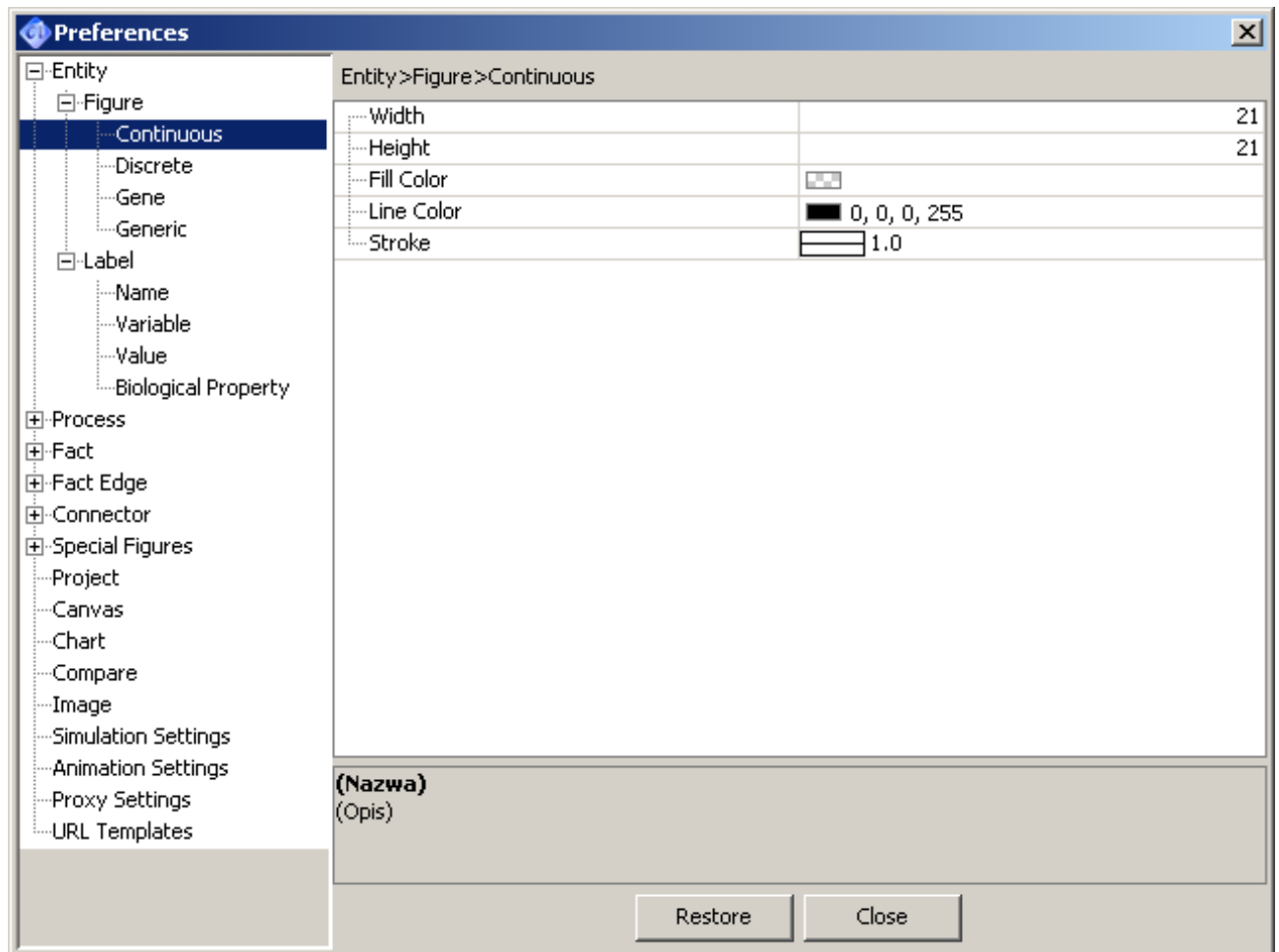

With the Preferences dialog, you can set the global properties of Cell Illustrator. The settings are stored as user preferences and apply also the next time you start the application. A change in the Preferences dialog is effective immediately and applies to new elements, canvas windows and simulations runs that are executed after the change unless the setting is one for the whole application, such as the grid size. In such a case, the setting applies to all (already existing and new) canvas windows. The *Restore Defaults* button restores the default (factory) settings for the selected branch of the option tree.

9.3 Compare

- In the Compare dialog the user specifies the details of the compare task
- Clicking the OK button compares (merges) two or more networks from the workspace. This operation compares selected networks and finds the common part of the networks (intersection), the differences between the networks and the sum of the networks (union).

- The active graph (*Main Graph*) is treated in a unique way during network merge: the common processes, entities and edges in the intersection network and also in the union network inherit their properties from corresponding processes, entities and edges from the *Main Graph*.
- The *other networks* are selected in the *Compare Graph* list.

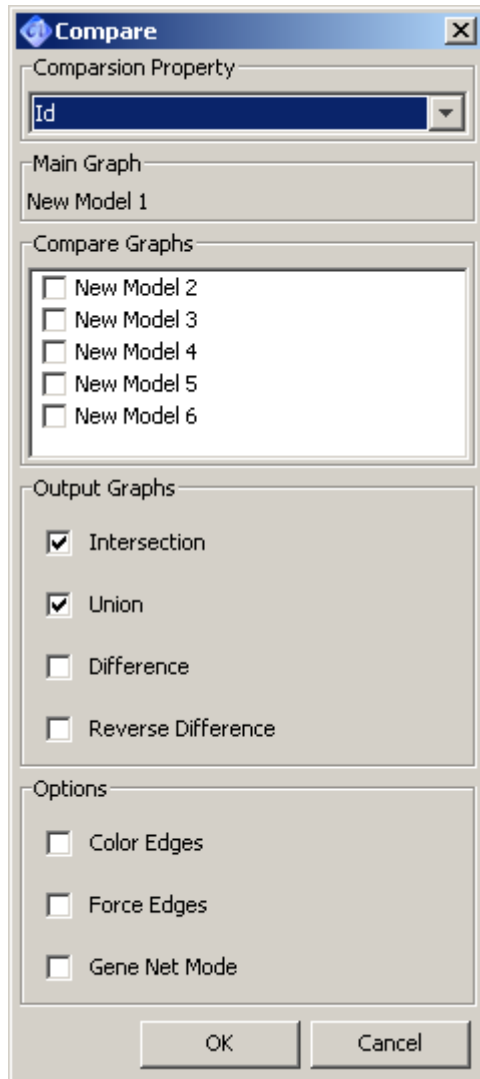

- The following different graph can be generated as Compare result:
 - *Union of Main Graph and Other networks*
 - *Intersection of Main Graph and Other networks*
 - *Difference between Main Graph and Other networks*
 - *Reverse Difference*, which is the difference between the union of *Other Networks* and *Main Graph*
- If *Color Edges* option is selected, all edges in *Main Graph* are marked by one color denoted by the *difference1* color (default is red) and all edges in *Network 2* are marked by another color denoted by the *difference2* color (default is green). The same colors are used for the corresponding edges in the resulting networks. The edges that are common in *Network1* and *Network2* are colored by the *intersection* color (default value is magenta).

- The default values for the predefined colors *difference1*, *difference2* and *intersection* can be defined in the **Preferences** dialog box, section Compare
- The edge colors resulting from the merging operation are persistent, i.e., you can save the output networks and view the edge colors after you open these files.
- The *Gene Net Mode* option should be selected for the correct comparison of fact edges. If this option is not selected the fact edges will be treated as fact vertexes.
- If the option *Force Edges* is on, the edges in the output graph are automatically completed by adding the source and target graph vertexes, even if the vertexes were removed by the merge operation. If this option is off incomplete graph edges will not be added to the output graph. This *Force Edges* option is important when calculating the difference of the *Main Graph* and *other networks*. Please note that if this option is on the difference operation gives higher priority to edges, rather than to their source and target vertexes. The difference excludes the common (intersecting) edges from the original *Main Graph* first. Then, all source and target vertexes are added for these edges that are left. This means that a common (intersecting) entity or process might be in the difference network, if *Force Edges* is on.

Identity Definitions:

- Equality between two graph vertexes (entity or process): two elements are equal if values of the property selected in *Comparison Property* (e.g. *Name*, *ID*, etc.) is equal.
- Equality between two edges: two edges are equal if their corresponding source and target are equal according to the above definition of the relation of equality between the objects.

Constraints:

- Two or more models must be opened in the workspace.

9.4 Manage User Databases

In this window you can create your own CSMLDB database from a set of CSMLDB files. You can also control or remove already existing databases.

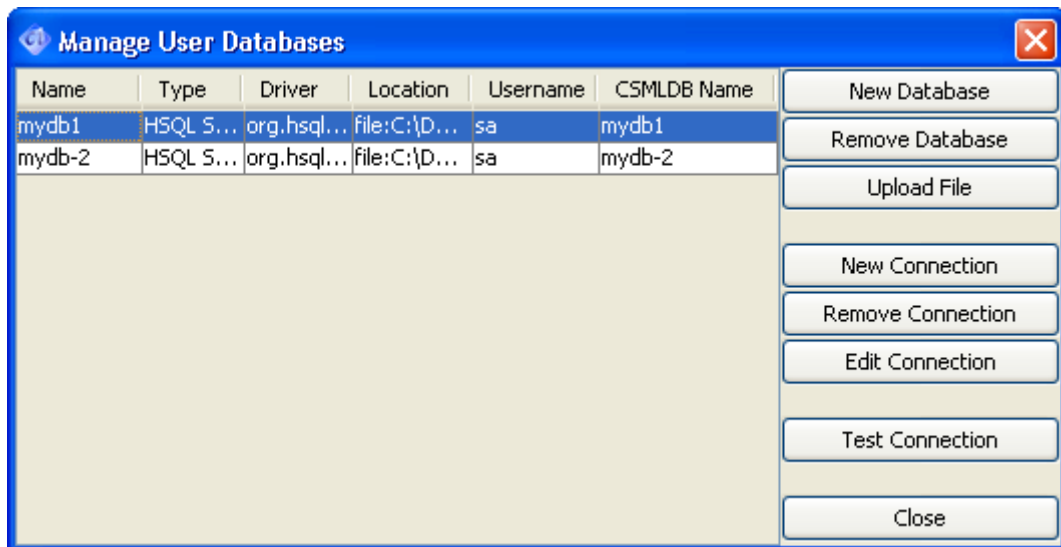

All created CSMLDB databases are listed in the table. The list can be controlled by the buttons on the right side of the dialog box, which are described below

9.4.1 New Database

Creates a new CSMLDB database from a CSML file. You can create two types of databases: standalone or server.

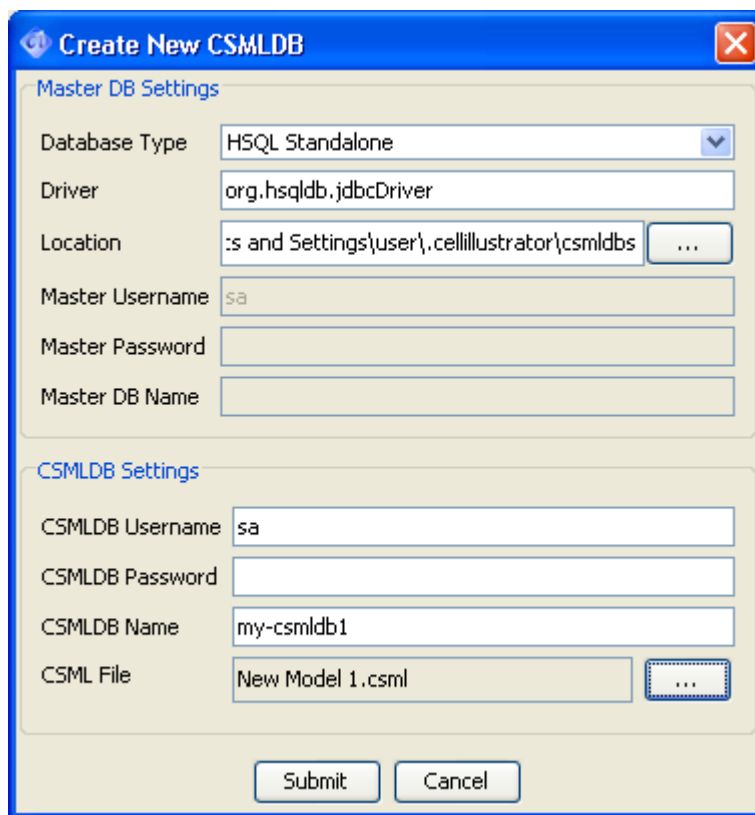

To create a standalone database:

- In *Database Type* choose *HSQL Standalone*

- In *CSMLDB Name* specify the name of the database. Make sure that a database with the same name does not exist on the database server.
- In *CSML File* select a CSML file from your local disk
- Optionally you may specify the other properties: *Location* – the directory where the database file will be saved, *CSMLDB Username* and *Password* for the database to be created.

Press the *Submit* button. This will create a standalone HSQLDB based database. Physically it will be a subdirectory with the name defined in *CSMLDB Name* field, which includes a set of files. The main file is a binary file and has the extension *.data*.

To create a server CSMLDB database:

- You must have a running database server. PostgreSQL, MySQL and, HSQLDB database servers are supported.
- In *Database Type* choose the desired database type
- Specify the *Master User/Password* and *Database*. This data will be used for the first login to the database server and to create the database. The *Master User* must have the privilege to create databases.
- In CSMLDB Settings, enter the *CSMLDB User Name/Password*. It must already exist in the server database. It can be the same as the *Master User*. The *CSMLDB User* will be used to connect to the database and perform all operations (query data, upload other CSML files etc.)
- In *CSMLDB Name* specify the name of the database. Make sure that a database with the same name does not exist on the database server.
- In *CSML File* select a CSML file from your local disk

9.4.2 Remove Database

Removes the selected database. It will erase all data from the selected database (if possible) and remove its item from the list.

9.4.3 Upload File

Adds all elements from CSML file to the selected database.

9.4.4 New Connection

Establishes a connection to an existing CSMLDB database.

9.4.5 Remove Connection

Removes a connection from the list.

9.4.6 Edit Connection

Allows for changing the properties of the db connection, such as db name, port, user name, password, etc.

9.4.7 Test Connection

Performs a connection check. The program tries to connect to the selected database and checks how many elements are in the entity and process tables.

9.5 Chart Window

A *Chart Window* presents how element values change over time in the course of simulation and the time dependence of one or more element variables in a chart.

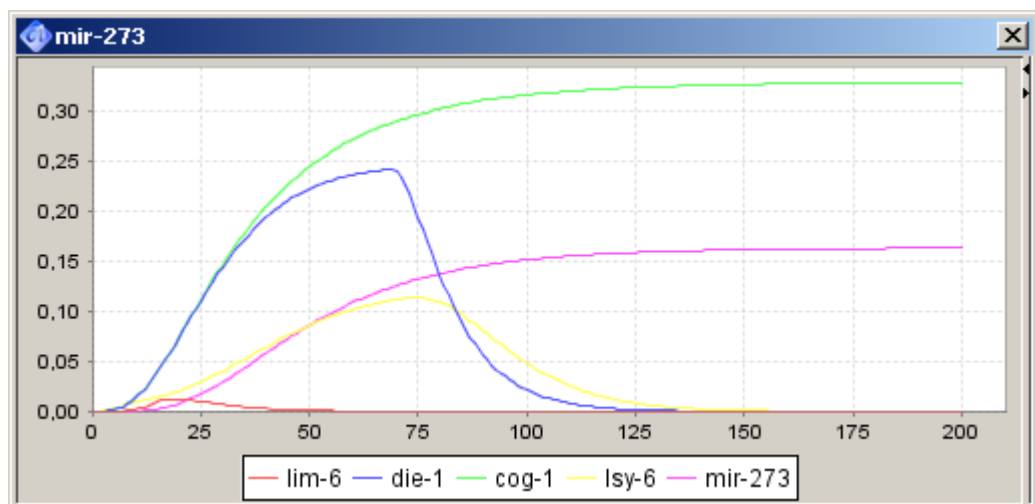

After simulation is started the *Chart Windows* appear. Each *Chart Window* contains the list of the plots defined in the [Chart Settings](#) frame. The *Chart Window* enables you to:

- Display plots with time series of entities, processes, connector values,
- Choose which of the plots are displayed or hidden,
- Customize chart and plot properties (set colors, fonts etc.),
- Zoom in, zoom out and auto range axes,
- Save *Chart Window* as PNG files,
- Print chart,
- Rasterize (freeze) a specified chart for later analysis or comparison,
- Copy the time series to system clipboard in a tab-separated text format. You can paste the chart data to another application, e.g., Microsoft Word or Excel

The *Chart Window* consists of the *Chart Panel* with the time series plots, the *Element List Panel*, and the popup menu.

9.5.1 Chart Panel

The *chart panel* presents how element values change over time in the course of simulation and the time dependence of one or more entity variables in a chart.

Chart Panel update interval depends on the mode of simulation:

- in the *Step* mode: for each step the *Chart Window* is updated,
- in the *Play* mode: update by each *Chart Update Interval*, default is one update per 1 Petri net time,
- in the *Fast Play* or *Max Speed* mode chart updates are done rarely: each time the time series increases by 10% or 50% respectively in comparison to the last updated time and at the end of simulation.

You can see the value of the data point once you move the mouse cursor over it. You can zoom into a chart area by dragging the mouse over this area from upper left to the bottom right corner. To reset the original size drag the mouse in the opposite direction from the bottom right to the upper left corner.

9.5.2 Element List Panel

The element panel contains the list of elements displayed in the chart. It consists of 3 columns: *Name*, *Show*, *Color*. In this panel you can:

- Show or hide the plot associated with a given element by clicking on the *Show* cell of a given element.
- Customize colors of data series in the chart by clicking on the *Color* cell of a given element.

9.5.3 Popup menu

Right-click on the chart control opens a popup menu where you can customize the chart display:

- *Properties* - set chart visualization properties.
- *Save As* – save the chart in PNG file.
- *Print* – print image on printer
- *Zoom In/Zoom Out* – specify the range for x and y axis. Only the data points that fit that range will be displayed
- *Auto Range* – Automatically adjusts the range of X and Y axis
- *Rasterize* - creates a window that is a snapshot of the chart. The snapshot is not updated during simulation. If you close it, the rasterized chart is destroyed. In contrast, if the original chart is closed, it just becomes hidden and reappears at the simulation start.
- *Copy To Clipboard* - Copy the time series to system clipboard in a tab-separated text format. You can paste the chart data to another application, e.g., Microsoft Word or Excel

9.6 Keyword Search

Using this dialog, you can locate elements (entities, processes and connectors) containing the specified text in one of their properties. The keyword search is performed by execution of the following steps:

- Enter a search string into the *Search For* edit box,
- Select search options using the checkboxes
- Select the properties to be searched for, in the *Search In* panel.
- Press the *Find* button.
- Left click an item in the *Search Result* list to select the elements

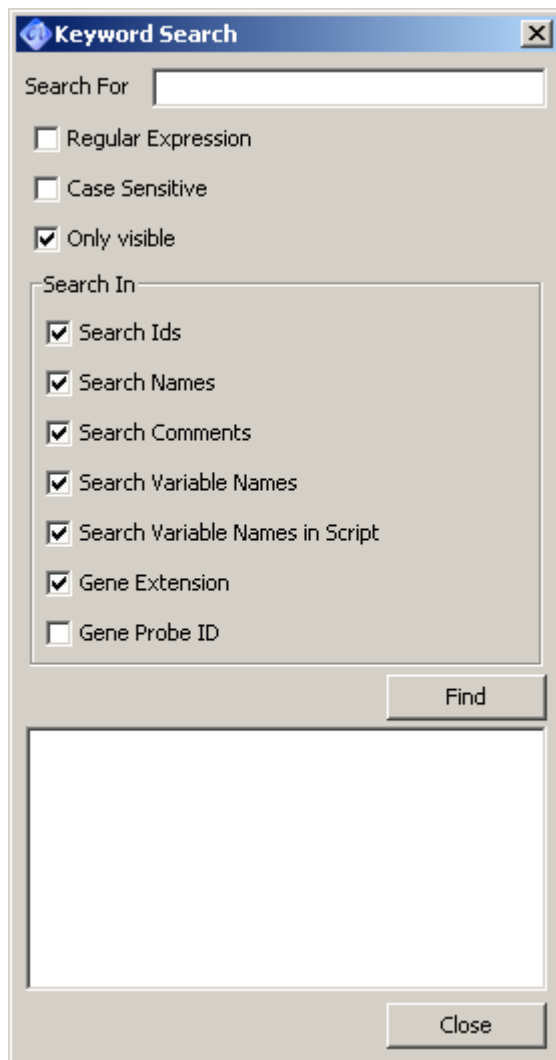

The *Keyword Search* is a modeless dialog. After finding an element, the user can switch back to the canvas window and edit the element without closing the *Keyword Search* window.

- Regular expressions can be used to find groups of similar elements.
- The following object types can be found: entity, connector, process.
- You can search in the following element properties: element name, element comment, entity variable name, variable names in scripts, gene extension, gene id
- Elements found in the search process are displayed in the *Search Results* list box at the bottom of the dialog. Also, the number of found objects is displayed above the list box.
- Clicking an item in the *Search Results* list box selects the corresponding element in the workspace. CTRL+click (Apple+click on Mac) and SHIFT+click allow for selecting/deselecting multiple items.
- To select an object, the canvas that has been searched must be active. If the active canvas is changed after the search, the *Search Results* list is cleared.
- The *Close* button dismisses the dialog window.

9.7 Path Search

Using this dialog, you can find sub-networks around the specified entity or entity-to-entity paths. The path search is done in the following steps:

- Select an entity in the *Search From* combo box.
- Select a target entity in the *Search To* combo box. This step is optional. Leave the *Search To* field empty, if you want to find a sub-network around the specified entity.
- Specify the *Number of Edges* to be searched for.
- Specify the search *Direction*.
- Specify the auxiliary options *Passing Vertices*
- Press the *Execute* button. This will display the [Path Search Results](#)

frame

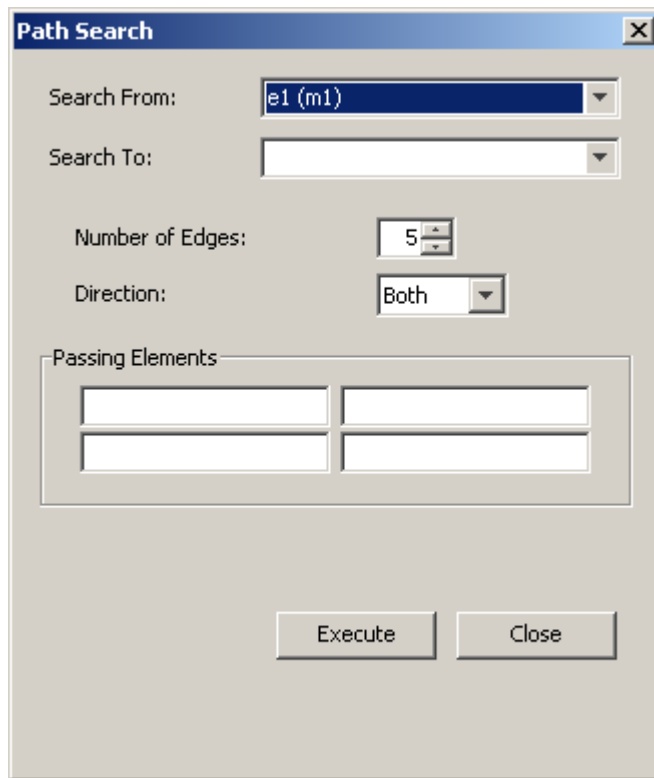

The *Path Search* dialog consists of the following controls

9.7.1 Search From Combo Box

In this combo box you can select the starting entity for each search. This combo box contains list with all entities in the active canvas.

Each entity is represented as a pair *Entity Name* and *Entity Variable Name* in the entity list. The additional *variable name* is useful to handle ambiguous situations. In some cases, two entities may have the same *Entity Name*, but they will possess different *Variable Names*.

9.7.2 Search To Combo Box

In this combo box you can select the target entity for each search. This combo box contains the list with all the entities in the active canvas.

If this field is empty, the target entity can be any entity in the canvas and the search results will include all paths beginning in the *Search From*.

If this field is not empty the search results will include only those paths that start in the *Search From* entity and end in the *Search To* entity.

Use this field, if you want to find a path between two entities (entity-to-entity paths) only. Otherwise, if you want to find a subnetwork around the starting entity leave this field empty.

9.7.3 Number of Edges

In this field you specify the number of edges to be searched for. To search for the nearest neighbors only, specify 1. To search for the nearest neighbors plus their nearest neighbors specify 2. The larger the number of connectors the more search results will be found.

9.7.4 Direction Combo Box

In this combo box you specify the search direction. You may choose one of the following 3 possibilities:

- Forward - to search for output (target) entities/processes only.
- Reverse - to search for input (source) entities/processes only.
- Both to search for any connected entities/processes.

9.7.5 Passing Element

A *Passing Element* is an entity or process that must be included in *the Search Results* paths. You may define up to 4 *Passing Elements*, by specifying their names in the edit boxes.

9.7.6 Execute Button

This starts the search with the specified options. The discovered paths are displayed in the *Path Search Results* frame.

9.8 Entity List Search

Using this dialog, you can locate a subnet by specifying a list of entity names.

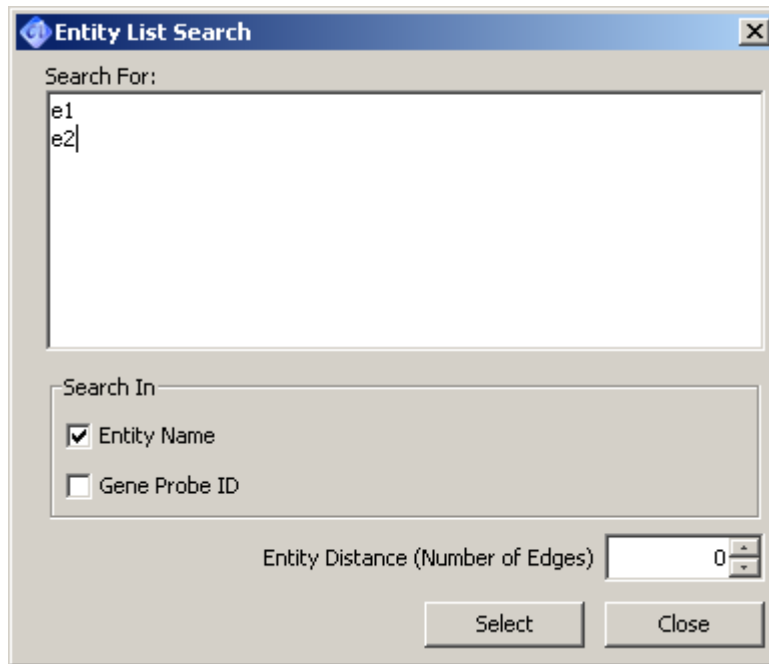

The search is done in the following steps:

- Open the *Entity List Search* dialog box.

Note: The *Search For* edit box is initialized by the names of the currently selected entities. This is useful if you want to search for a subnet that consists of the selected entities and their connections within a given distance of edges.

- Enter (paste) the list of names into the *Search For* edit box

Note: After copying nodes of one canvas, you may paste the list of their names into any text editor, including the *Search For* edit box.

- Select where to search by choosing the options in the *Search In* box
- Specify the *Entity Distance* in edges. For the default value 0 no edges will be selected. If the specified edge distance is larger than 0 then all paths (entity-edge-entity-edge-entity-...) connecting found entities within the given number of edges will be selected. The larger the *Entity Distance* value the more elements will be selected)
- Press the *Select* button. The Entity/probe names might be separated by any standard separator, such as space, tab, coma, semicolon, new line. The entity name list to be searched for can be copied from an external database or spreadsheet or from another canvas.
- The found sub-network is highlighted on the canvas with the selection color (green is the default). After inspecting the search results on the canvas, you may change the search criteria (e.g. the *Entity Distance*) and resume the search by clicking the *Select* button.

The *Close* button dismisses the dialog window.

9.9 Reference Simulation

This dialog is opened by invoking *Simulation / Run Reference Simulation*. Reference Simulation gives the user the ability to:

- insert reference data contained in CSV file into the simulation run.
- visually compare simulation results versus reference data.

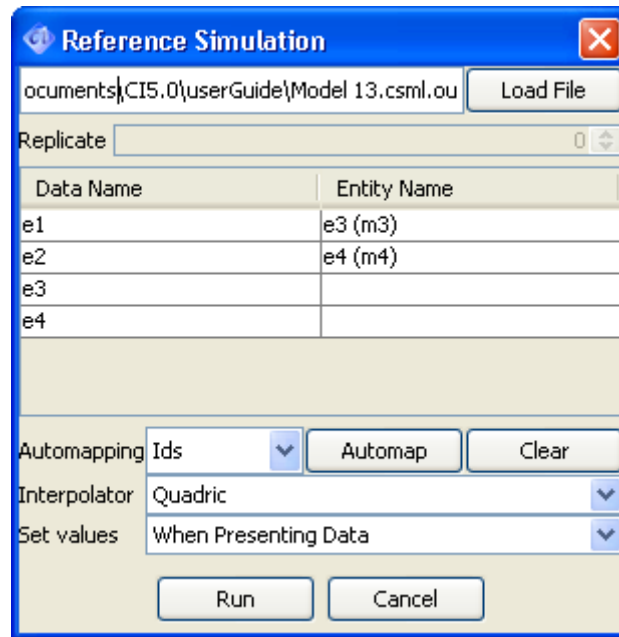

To setup a reference simulation:

- Load the data file. The file should be a tab-separated values file with time series data stored in columns. The first row must have the column headers (names). The first column must be the time column, while the next columns should be identified by unique names.
- Map the column names from data file to entity names of the simulated model. The buttons *Automap* and *Clear* are helpful for this
- Choose the way how the reference data should be displayed on charts in the *Interpolator* combo-box (optional step)
- Choose the method and moment of setting values from the list of available choices: Only At Simulation Start, When Presenting Data, At Each Step.
- Press the Run button. If the Reference Simulation setup was correct, the simulation will be started in the CI workspace.

- Use the standard buttons *Step Play*, *Play*, *Pause*, *Fast Play*, etc. to continue the simulation in the usual way; the results of the simulation are displayed on charts and/or saved to log file.

9.10 SECG Passing Parameters

This dialog allows selecting the entities which should be treated as parameters in the passing parameters simulation. You can specify the parameter range and interval in a table with available entities.

For example, in the bellow window, the e1 and the e5 entities were selected to be parameters. The simulation will be run for each combination of the parameters. In this case entity e1 will have following values 10.0, 12.5, 15.0, 17.5, 20.0, and the entity e5 following 0, 1, 2, 3, 4, 5.

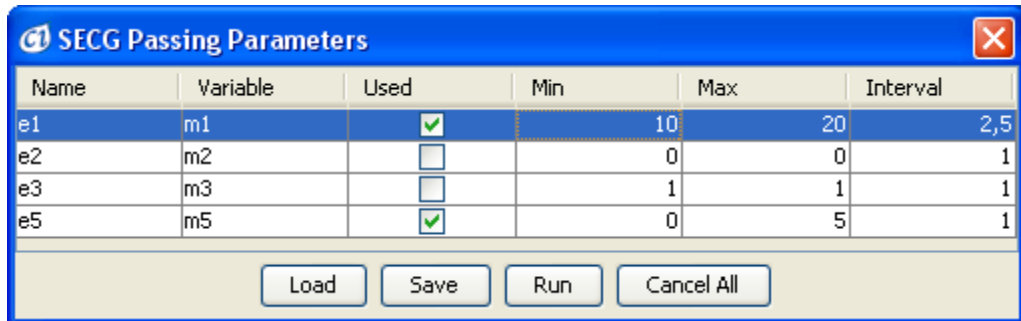

The parameter settings can be saved and load to a text file using the Load and Save buttons. The simulation is executed by pressing Run button. The last button with name Cancel All, cancels (stops) all SECG Passing Parameter simulations,.

9.11 Parameterized Simulation Results

This dialog box is displayed after the SECG parameter simulation has finished. It enables you to select what should be viewed and how.

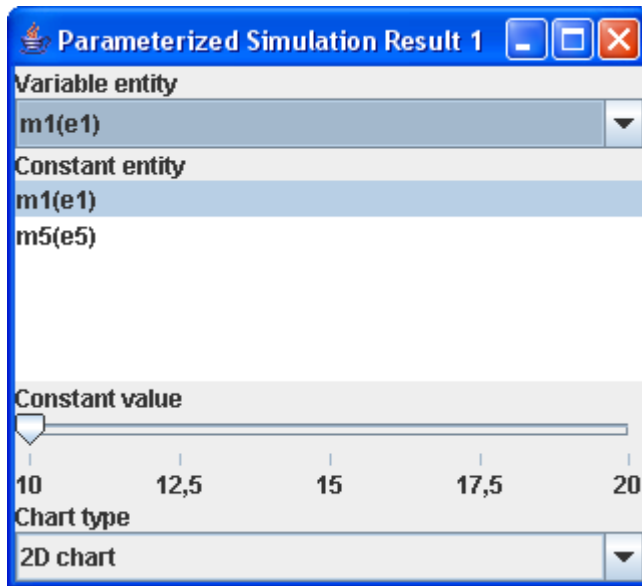

The *Chart Type* combo box allows specifying what kind of chart should be used - a 2D chart or a 3D grid or line chart.

In the 3D chart, the simulation results shows the dependency of selected entity values time series on one and only one parameter value, while other parameters are fixed (constant). Which parameter dependency is to be reflected on the charts is selected by choosing the entity in the *Variable Entity* combo box. The actual values of the other parameters are selected by choosing the entity in the list and selecting its value using the *Constant Value* slider.

9.12 About Cell Illustrator

About Cell Illustrator is a modal dialog that contains tabs: *Version*, *License Information*, *Licensed Modules*, *License*, and *Third Party Components*.

- *Version* contains the version number and the copyright information.
- *License* contains the End User License Agreement text.
- *License Information* sheet displays the user's account data on the give Cell Illustrator Server, including license type, expiration date, etc. and the *Reseller* contact data.
- *License Modules* sheet displays the list of modules that are accessible to the user..
- *Third Party Components* sheet displays information about software components used in Cell Illustrator.

10 Other

10.1 CSO Class Tree

The Cell System Ontology (CSO) is a dictionary that contains terms for the specific biological properties, such as biological class and location of the entity, process or connector. For each biological property there is a limited number of choices defined in the CSO Class Tree. The *CSO Class Editor* facilitates browsing/searching through the hierarchy of the terms and finding/selecting the proper one.

With this editor you can:

- Select one element from the CSO hierarchy list of available choices
- Browse through the CSO dictionary
- Find a term in the CSO dictionary, the edit box shows after you press any key

To find a proper CSO term:

- Enter one or more characters into the edit box. You can use special characters such as:
 - o * - replaces many characters
 - o ? – replaces single character
- The possible choices that start with the entered characters are displayed in the tree, you can navigate between them using up and down arrow on your keyboard

10.2 Script Editor

An advanced user of Cell Illustrator may need to write a custom function to specify changes of a property value. With the *Script Editor*, you can write a scripts to define:

- *Threshold, Speed, Updater, and Firing Rule* property of a connector,
- *Activity, Speed and Delay* of processes as well as
- *Initial Value* of entities.

The scripting framework which executes the scripts can be quite slow. Fortunately, most of the scripts in Cell Illustrator models are simple mathematical expression, e.g. $m1*m2$, $0.1*m1$. Thus, highly customized *simplemath* scripting language was developed for this project and added to the scripting framework. Additionally two types of scripting languages based on Java can be used: *java* and *java-bulk*. For those types the scripts are written in Java, then compiled into java byte-code and executed within the scripting framework as normal java method.

All available *Scripting Languages* are listed in the table below from the fastest (*simplemath*, *java-bulk*) to the slowest (*js – javascript*, *pnuts*).

Language	Properties
<i>simplemath</i>	<p>Default Scripting Language</p> <p>Quite restrictive syntax</p> <p>Allows writing mathematical expressions and some logical expressions</p> <p>Provides many mathematical functions (basically it allows doing operations as medium level calculators)</p> <p>Very fast (basically one java function is invoked for each operation), quite similar performance to java for not very complex scripts.</p> <p>Most of the scripts can be used later in SECG</p> <p>The syntax supported by <i>simplemath</i> script is summarized in the chapter below.</p>
<i>java-bulk</i>	<p>Identical to java, but all scripts are compiled at once, so the generation of engine is much faster than java.</p> <p>Fast. Almost as fast as <i>simplemath</i>. Especially for large models with many java scripts it is much faster than java.</p> <p>However there is one drawback: If the script has errors, the error report can only show the compile error but cannot point out the exact place where the error script is written, i.e. kinetic script in process p1.</p> <p>The recommended usage is to switch to <i>java</i> script to check the cause of error and switch back to <i>java-bulk</i> after the model compiles successfully.</p> <p>Most of the scripts can be used later in SECG.</p> <p>Requires JDK, JRE is not enough.</p>

<i>Java</i>	<p>Allows for writing scripts in normal java code. The code is placed inside a java function for compilation and execution. Each script is placed into a separate class file.</p> <p>Not fast, slower than <i>java-bulk</i>. Recommended for small models only. Although <i>Java</i> is fast during execution, it is slow at startup. Creation of the simulation engine may take a lot of time, since each of scripts is compiled separately.</p> <p>Most of the scripts can be used later in SECG.</p> <p>Requires JDK, JRE is not enough.</p>
<i>js</i>	<p>Allows for writing scripts in js (<i>javascript</i>) language.</p> <p>Not fast, not so fast as java at execution time.</p> <p>More simple syntax than Java.</p> <p>Not compatible with SECG. Scripts created in js might not run with SECG.</p>
<i>Pnuts</i>	<p>The <i>Pnuts</i> script is supported mainly for the backward compatibility to previous Cell Illustrator versions. In CI5.0 the running speed of <i>Pnuts</i> is very slow, since the implementation of <i>Pnuts</i> is not customized to the java scripting framework.</p> <p>When loading the model created in CI4.0 to CI5.0, it is recommended to switch to other supported script language in CI5.0.</p> <p>In most cases the scripts will work just after switching the script from <i>Pnuts</i> to other language in the <i>Simulation Setting</i> dialog or <i>Element Setting</i> dialog.</p> <p>If a model contains a few complicated scripts, one solution is to set <i>Pnuts</i> as language for these complex scripts and set the default scripting language as <i>simplemath</i> in simulation settings dialog. In such a case the slow <i>Pnuts</i> executor will be used for the few complex scripts only, while rest of the scripts will be executed by using the fast <i>simplemath</i> executor.</p>

Note: Very *simple scripts* (such as ‘1’, ‘true’, ‘2.434’ or ‘m1’), are not executed by evaluating the script in the selected language, but they simply return the value as it is written. The definition of *simple scripts* is summarized in the next chapter.

10.2.2 Simple Scripts Syntax

Simple scripts are scripts that are treated as plain text by the simulation engine. Such scripts are neither compiled nor executed, but the simulation engine replaces the script by a value. Thank to that *simple scripts* are independent from *scripting*

10.2.3 Simplemath Syntax

The *simplemath* language is dedicated for writing math scripts, which will be executed very fast by the simulation engine. A *simplemath* script consist of exactly **one expression** that may include tokens listed in the table below:

<i>Simplemath</i> tokens			
TOKEN	Description	Definition	Example
VARIABLE	Variable Label identifying an entity value	('a'..'z' 'A'..'Z' '_') ('a'..'z' 'A'..'Z' '_' '0'..'9') *	m1, m2, m3, etc
VALUE	Number	('0'..'9') + ('.' ('0'..'9') *) ? '.' ('0'..'9') +	123.456
OPERATOR	Algebraic operator:	ADDITIVEOP : '+' '-' MULTIPLICATIVEOP : '*' '/' '%'	m1+2 m2*m3 m2/m3 m1%m2
UNARY	Unary sign operator:	ADDITIVEOP : '+' '-'	-m1 -6.5
COMPARATOR	Comparator operators: equal, not equal, less than, greater than	EQUALOP : '==' '!=' NOTEQUALOP : '<' '>' '<=' '>='	m1 == m2 m1 >= 2

LOGICAL	Logical operators	OROP : ' ' ANDOP : '&&'	m1 > 1 m2 > 1 m1 > 1 && m2 > 1
FUNC	Functions and Constants,	rand random gauss gaussian PI E sin cos tan asin acos atan ceil floor round exp log abs sgn signum min max pow atan2 beta gamma	rand() sin(m1) PI E pow(m1,2) hill(1,2,3,4)

		median SMass LSMass LSMass2 hill err	
IF	Question mark operator	QMARK : '?' ELSE : ':'	$m1 > 0.5 ? 0 : 1$
Parentheses	Brackets)	LPAREN : '(' ; RPAREN : ')'	$(1+m2)/2$
WHITESPACE	Spaces	WHITESPACE : ('\t' ' ' '\r' '\n' '\u000C')+ { \$channel = 99; } ;	

10.3 Kinetic Styles Editor

The *kinetic style* is a property of the process. It allows to define the mathematical formula for the process speed, i.e. how the value of the input/output entities will be increased/decreased after each simulation step the simulation.

There are several kinetic styles which can be divided into following groups:

- User defined *Kinetic Script* – in these styles (*custom, connectorcustom*) the user may define the process speed by its own custom script.
- Predefined *Kinetic Script* – in these styles the script is generated automatically from the parameters provided by the user.
- Process specific styles – in these styles (*custom, MichealisMenten, Hill*) the speed is the same for all connected connectors, i.e. all connected entities will be increased/decreased by the same value (*delta*)
- Connector specific styles - in these styles the speed for each connected connector can be different, i.e. each connected entities might be increased/decreased by a different value (*delta*). The number of parameters for such a connector specific styles is proportional to the number of connectors connected to this process.

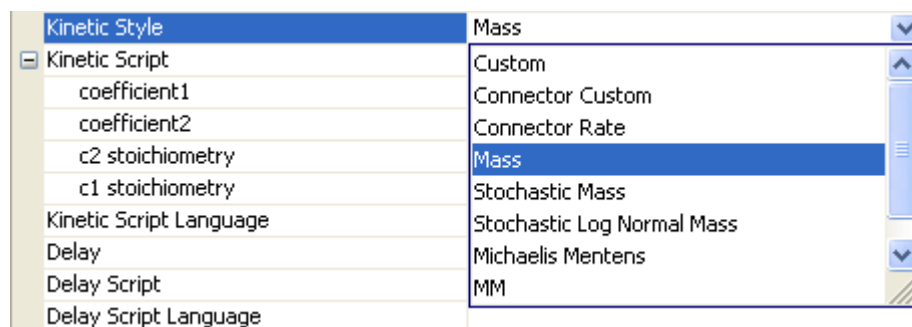

Each kinetic styles requires one or more parameters that are defined in the *Kinetic Script* tree below.

The table below gives more details on the kinetic style concept by describing the mathematical formula that is used to calculate the entity value change (*delta*) for all the different kinetic styles. Also, the parameters used for each kinetic style are listed in the table.

Kinetic style	Process type	Formula for the change value delta
Custom parameter: speed / add	continuous (speed calc style)	$\text{delta} = \text{speed} * \text{sampling interval}$
	discrete (add calc style)	$\text{delta} = \text{add}$
connector custom parameters: speed / add / update for each connector	continuous (speed calc style)	$\text{delta} = \text{connector_speed} * \text{sampling_interval}$
	discrete (add calc style)	$\text{delta} = \text{connector_add}$
Mass parameters: coefficient ₁ , coefficient ₂ , stoichiometry for each connector	continuous (speed calc style)	$\text{delta} = m_product * \text{coefficient}_1 * \text{coefficient}_2^{[\text{number_of_input_entities}] * \text{stoichiometry}} * \text{sampling_interval}$ <p>where m_product is the product of all input entity values. For the input entity variables (m₁, m₂, ..., m_n) $m_product = m_1 * m_2 * \dots * m_n$</p>
	discrete (add calc style)	$\text{delta} = m_product * \text{coefficient}_1 * \text{coefficient}_2^{[\text{number_of_input_entities}] * \text{stoichiometry}}$ <p>where m_product is the product of all input entity values. For the input entity variables (m₁, m₂, ..., m_n) $m_product = m_1 * m_2 * \dots * m_n$</p>

stochastic mass parameters: coefficient ₁ , coefficient ₂ , standard deviation and stoichiometry for each connector	continuous (speed calc style)	delta is randomly generated using the Gaussian distribution with the calculated delta_mean and specified standard deviation. delta_mean is calculated using the formula for the mass kinetic style: delta_mean = delta_mass (coefficient ₁ , coefficient ₂ , stoichiometry)
	discrete (add calc style)	delta is randomly generated using the Gaussian distribution with the calculated delta_mean and specified standard deviation delta_mean is calculated using the formula for the mass kinetic style: delta_mean = delta_mass (coefficient ₁ , coefficient ₂ , stoichiometry)
connector rate parameters: rate and stoichiometry for each connector	continuous (speed calc style)	delta = rate * stoichiometry * sampling_interval
	discrete (add calc style)	delta = rate * stoichiometry

10.4 SECG

Simulation Engine Code Generator (SECG) is a simulation engine that enables you to simulate the selected model in a special way. SECG performs the simulation in the following steps:

- Generate the Java source code that represents the Petri Net model of the selected canvas
- Compile the source code using Java Compiler (javac)
- Execute the compiled program
- Save simulation log

Thanks to this approach large models can be simulated much faster than using the default simulation engine included in CI.

Note: For SECG the java compiler must be available and path to it should be setup correctly in Preferences dialog box, Simulation Settings panel.